

EnverTec®

COMPOSITE POLYMER INSULATORS MV – HV

INSULATORS M.V.- H.V.

Standard Insulators and Specific Developments.

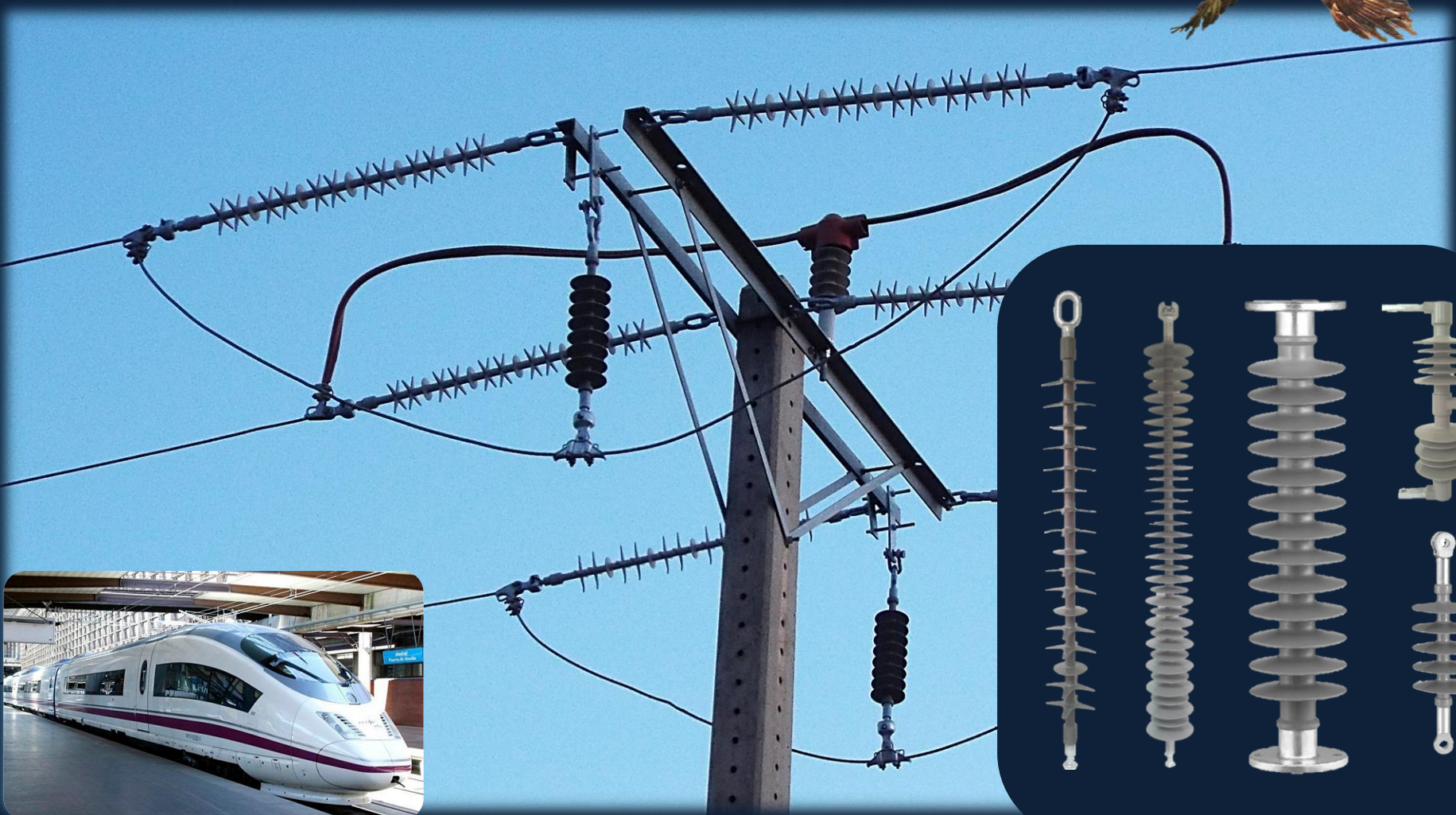

INSA_012025



INTERACTIVE CATALOGUE



RANGE 15kV – 400kV.

www.birdprotectionsystems.com

PREFACE

GENERAL CONTENTS

SALES REF.



ISOLATION SYSTEMS IN MV / HV NETWORKS 15kV - 400kV



CARACTERISTICAS TECNICAS – TECHNICAL DATA – CARACTERISTIQUES TECHNIQUES – ESPECIFICAÇÕES TÉCNICAS

NORMAS – STANDARD – NORMES – LEGISLAÇÃO: UNE – 21909/CEI – IEC-1109 / 61952

Tensión Nominal – Rated Voltage – Tension Nominale – Tensão Nominal: 12 to 400 kV

CARGA MECÁNICA – SPECIFIED MECHANICAL LOAD – CHARGE MÉCANIQUE – CARGA MECÂNICA:

Aisladores de Suspensión – Suspension Insulators – Isolateurs de Suspension – Isoladores Suspensão: 45 a 210 kN.

Aisladores de Apoyo – Pin/Post Insulators – Isolateurs Support – Isoladores Apoio : 3 a 20 kN

HERRAJES – METAL FITTINGS – FIXATIONS MÉTALIQUES – FERRAGENS :

Construidos en Acero Forjado Galvanizado en Caliente. CEI 120 – CEI 61466 – CEI 60383

Forged Steel Hot Galvanizing . Standards IEC 120 – IEC 61466 – IEC 60383

Acier Forgé Galvanisé au Feu. Normes IEC 120 – IEC 61466 – IEC 60383

Aço Forjado com zinco em banho quente. CEI 120 – CEI 61466 – CEI 60383

RECUBRIMIENTO DE SILICONA – SILICONE COATING – COUCHE DE SILICONE – REVESTIMENTO DE SILICONE :

Caucho de Silicona HTV sin EPDM. Hidrófugo. Nivel Hc2.

Silicone HTV free of EPDM . Hydrophobicity Hc2.

Silicone HTV sans EPDM . Hydrophobicité Hc2.

Silicone HTV livre de EPDM. nível de rejeição umidade Hc2



NÚCLEO – CORE – STRUCTURE INTERNE – ESTRUTURA INTERNA :

Fabricado en Resina Epoxy reforzado con fibras de vidrio.

ERC Fiberglass-reinforced

Resine Epoxy Renforcée avec fibre de verre.

Resina Epoxy reforçado com fibras de vidro.



Tipos de Herrajes Metálicos disponibles hasta 160 kN

Types of End metal Fittings until 160 kN

Types de Fixations Métalliques disponibles jusqu'à 160 Kn

Ferragens Disponível até 160 kN



Nuestro Dpto. Técnico puede suministrar estos aisladores " Sobre Demanda " , bajo plano o especificaciones técnicas del cliente en Herrajes , Recubrimiento externo de Silicona , Línea de Fuga , características dimensionales y de diseño requeridas.

Our Technical Department can provide these insulators "On Demand" , on design or technical specifications of the customer in end metal fittings, external silicone coating, Creepage Distance, dimensions and design requirements.

Notre département technique peut fournir ces isolateurs sur demande, selon les spécifications techniques du client pour le dessin des parties métalliques , le dessin du revêtement externe en silicone, Ligne de fuite, les dimensions et les exigences de conception.

Nosso Departamento Técnico pode fornecer estes Isoladores "a pedido" , na concepção ou as especificações técnicas do cliente, em hardware, revestimento externo de silicone, Linha de fugas, dimensões e requisitos do projeto.



ISOLATION SYSTEMS IN MV / HV NETWORKS 15kV - 400kV



CATÁLOGO - CATALOGUE - CATALOGUE - TIPOS

Aisladores de Suspensión Alta Tensión hasta 300 kV

Suspension Insulators up to 300 kV - 210 kN

Isolateurs de Suspension Haute Tension jusqu'au 300 kV 210 kN

Isoladores Alta Tensão até 300 kV 210 kN



Aisladores de Apoyo Media Tensión hasta 38 kV 12,5 kN

Pin Insulators up to 38 kV 12,5 kN

Isolateurs Rigides M. Tension jusqu'au 38 kV 12,5kN

Isoladores Apoio M. Tensão até 38 kV 12,5 kN



Aisladores de Apoyo Alta Tensión 10 kV - 400 kV_ 3-20kN

Post Insulators 10 kV - 245 kV 3 -20 kN

Isolateurs de soutien haute tension 10 kV - 245 kV 3 -20 kN

Isoladores Apoio 10 kV - 245 kV 3 -20 kN

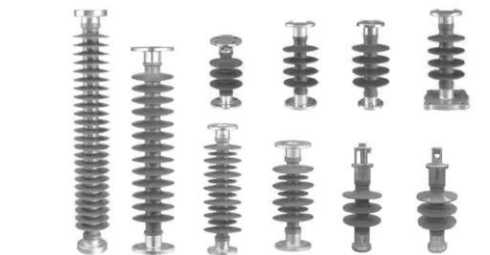

Desarrollos especiales bajo demanda. _ *Customized insulators* _ Isolateurs sur demande _ Isoladores "A Pedido".



Aisladores Para Ferrocarriles - Catenárias 20 kV - 72,5 kV

20 - 60 kN / Railway Insulators 20 kV - 72,5 kV 20 - 60 kN

Isolateurs Chemin du Fer 20 kV - 72,5 kV 20 - 60 kN / *Isoladores Ferroviarios 20 kV - 72,5 kV 20 - 60 kN*



Aisladores Brazo de Apoyo 10 kV - 145 kV 3 -10 kN

Post cross-arm insulators 10 kV - 145 kV 3 -10 kN

Isolateurs Support Rigides 10 kV - 145 kV 3 -10 kN

Isoladores Braço Apoio 10 kV - 145 kV 3 -10 kN



Colores disponibles en toda la gama : Gris , Rojo , Azul , ó según demanda - *Colors : Red , Gray , Blue , On demand.* - Couleurs : Rouge , Gris , Bleu , selon demande du client. *Cor: Cinza , Azul , Vermelho , "a pedido do cliente"*



ISOLATION SYSTEMS IN MV / HV NETWORKS 15kV - 400kV



> 1 000 000pcs Delivered 2014 - 2024
> 1.000.000 Aisladores suministrados.

GENERAL INDEX OF SOLUTIONS. New layouts and network adaptations

	<p>CHAIN INSULATORS <i>Suspension insulators 15-300kV</i> USE IN AERIAL LINES 15-300kV.</p>	<p>CAON®-KORWI®</p> <p></p>	
	<p>RIGID INSULATORS <i>PIN insulators up to 138kV</i> USE IN AERIAL LINES 15-138kV.</p>	<p>CAON®-KORWI®</p> <p></p>	
	<p>SUPPORT INSULATORS <i>Post insulators up to 400kV</i> USE IN SUBSTATIONS 15-400kV.</p>	<p>CAON®-KORWI®</p> <p></p>	
	<p>AVIFAUNA INSULATORS FOR ZEPHA USE <i>Bird protection insulators 15-72,5kV</i> USE IN AERIAL LINES- ZEPHA 15-72,5kV.</p>	<p>CAON®-KORWI®</p> <p> </p>	
	<p>POLYMERIC SPACERS <i>Polymeric Spacers 15-132kV</i> USE IN AERIAL LINES 15-132kV.</p>	<p>CAON®-KORWI®</p> <p> </p>	
	<p>BRIEF SUPPLY REFERENCES SUPPLIES REFERENCES</p>		



ISOLATION SYSTEMS IN MV / HV NETWORKS 15kV – 300kV



Model Index. New Aerial Lines and Network Adaptations

CHAIN/SUSPENSION INSULATORS CAON[®]-KORWI[®]

USE IN AERIAL LINES 15- 300kV.



Composite Suspension/Tension _ 15kV up to 300kV



POLYMERIC CHAIN INSULATOR FOR AERIAL LINES IN HIGH POLLUTION AREAS 15 kV 70kN
_ END FITTINGS CLEVIS-TONGUE - REF. **IDISNORTE-DISSUR 441249**

TECHNICAL DATA SHEET OF THE INSULATOR
Mod. : C1570CT

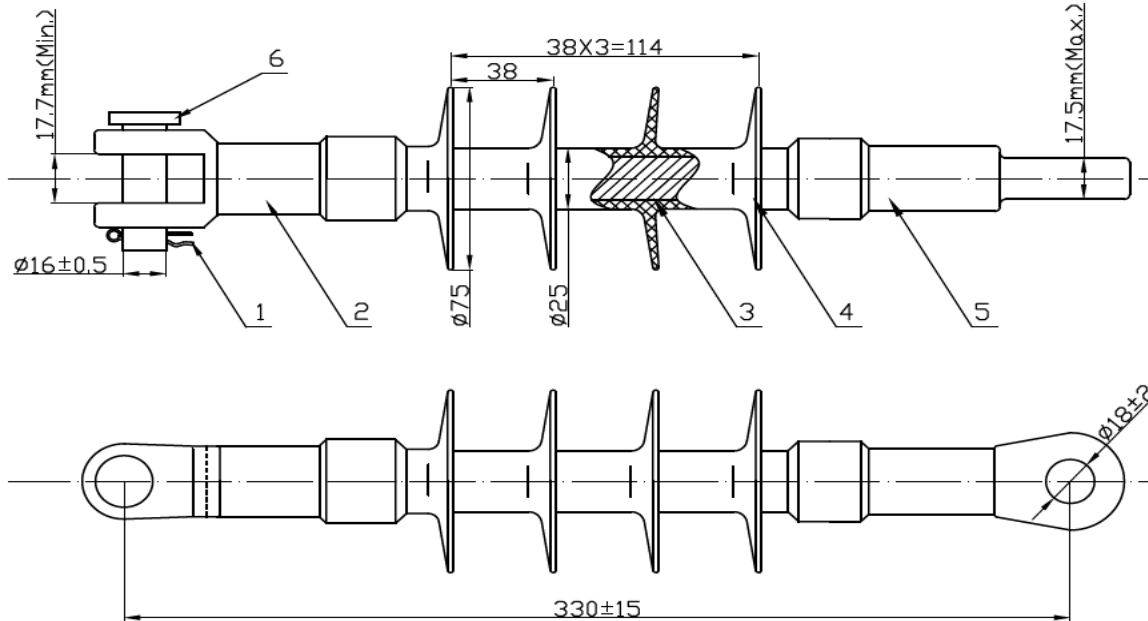

Main Characteristics:

- Suitable for High Contamination Areas.
- Warranty: 10 Years.
- Continuous HTV Silicone Coating.
- Production center certified ISO9001 – ISO14001.
- Hydrophobic Level Silicone HC2. Repels moisture accumulation.
- Reinforced Glass Fiber (ECR) Resin Core _ CME Routine 3500daN.
- Effective performance in high contamination areas.
- Hot-Dip Galvanized Fittings. HDG.

Mod.	Service Voltage	Creepage Dist.	Min. Protected Line	Mechanical Load	Test Voltages			
					POS. BIL	NEG. BIL	F.I./ WET	F.I/ DRY
C1570CT	kV	mm	mm	daN	kV	kV	kV	kV
Weight (kg)	15	355	200	7000	140	155	65	90

CHAIN INSULATORS



POLYMERIC CHAIN INSULATOR FOR AERIAL LINES IN POLLUTION LEVEL e. 20 kV 70kN _
END FITTINGS CLEVIS-BALL - REF. **IBERDROLA** U70YB20P

TECHNICAL DATA SHEET OF THE INSULATOR

REF.: U70YB20P - CODE 4803205

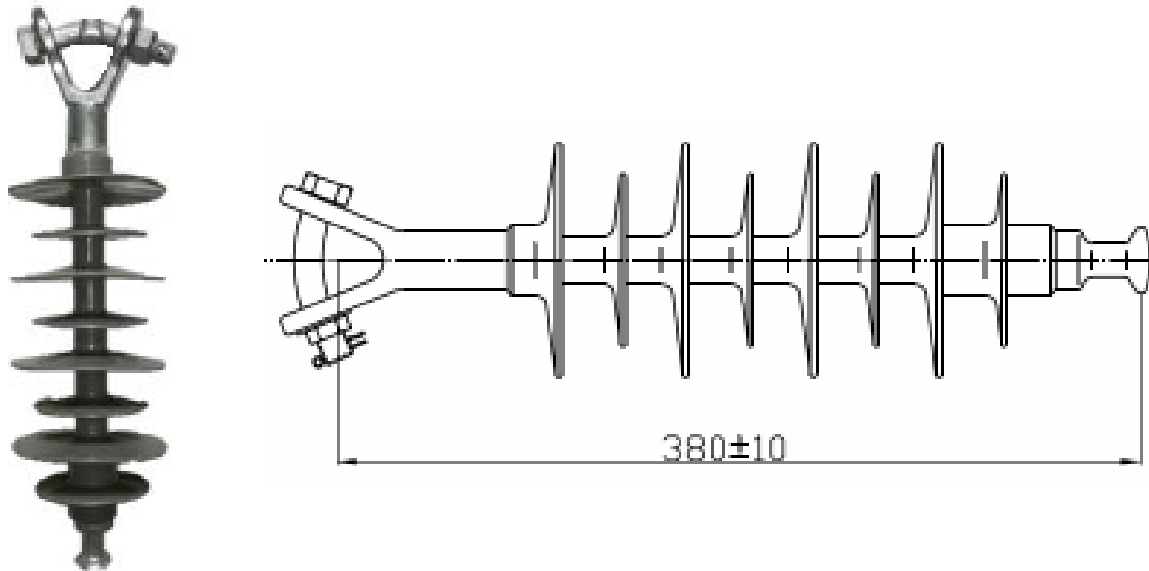

Main Characteristics:

- Single body insulator. Higher stiffness.
- Continuous HTV Silicone Coating.
- Hydrophobic Level Silicone HC2. Repels moisture accumulation.
- High Mechanical Efficiency Glass Fiber ERC 70 kN Core.
- Warranty: 15 Years.
- WEIGHT 1.45 Kg.

Cod.	Service Voltage	Creepage Dist.	Min. Protected Line	Mechanical Load	Test Voltages	
U70YB20P	U_r	<i>C.D.</i>	<i>Dry arc</i>	<i>SML</i>	1,2/50 BIL	50 Hz/WET
Drawing	kV	mm	mm	kN	kV	kV
GN0001697B	20	740	300	70	165	70



POLYMERIC CHAIN INSULATOR FOR AERIAL LINES IN POLLUTION LEVEL *e* . 20 kV 70kN _
END FITTINGS TONGUE-TONGUE -REF. **IBERDROLA** U70PP20P

TECHNICAL DATA SHEET OF THE INSULATOR
REF.: U70PP20P – CODE 4803206



Illustrative image of a similar insulator.
Not representative.

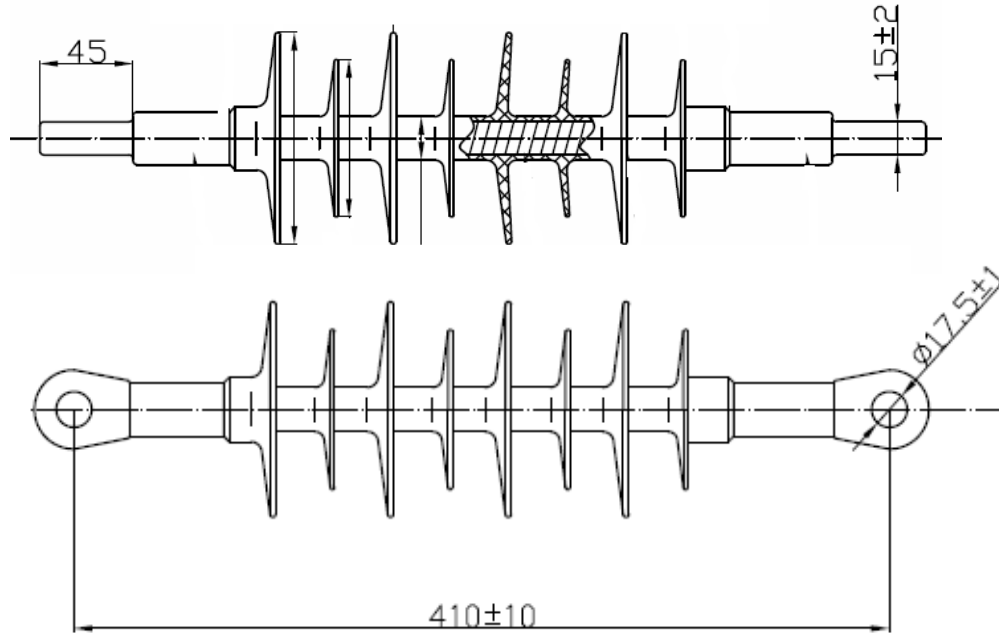

Main Characteristics:

- Single body insulator. Higher stiffness.
- Continuous HTV Silicone Coating.
- Hydrophobic Level Silicone HC2. Repels moisture accumulation.
- High Mechanical Efficiency Glass Fiber ERC 70 kN Core.
- Warranty: 15 Years.
- WEIGHT 1,00 Kg.

Cod.	Service Voltage	Creepage Dist.	Min. Protected Line	Mechanical Load	Test Voltages	
U70PP20P	<i>U_r</i>	<i>C.D.</i>	<i>Dry arc</i>	<i>SML</i>	1,2/50 BIL	50 Hz/WET
Drawing	kV	mm	mm	kN	kV	kV
GN0001695B	20	740	230	70	165	70

CHAIN INSULATORS



POLYMERIC CHAIN INSULATOR_FOR AERIAL LINES IN POLLUTION LEVEL d. 24 kV 70kN -
END FITTINGS EYE-BALL -REF. **ENDESA** 6702341 / TAM 300092

TECHNICAL DATA SHEET OF THE INSULATOR

REF.: 24/70 EBA

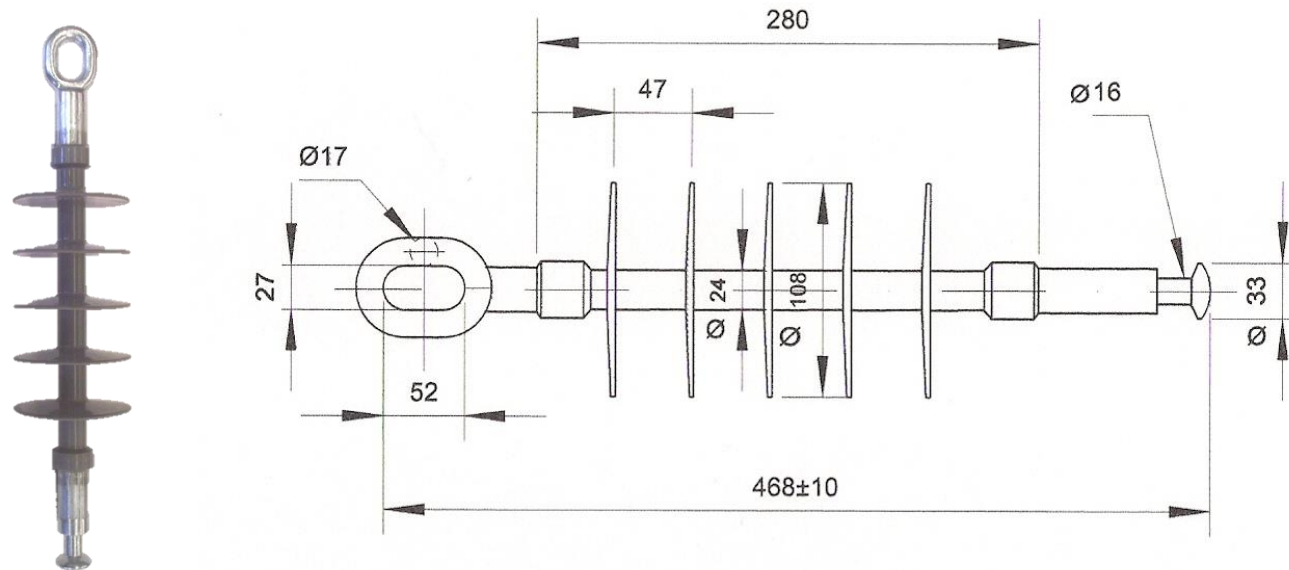

Main Characteristics:

- Single body insulator. Higher stiffness.
- Continuous HTV Silicone Coating.
- Hydrophobic Level Silicone HC2. Repels moisture accumulation.
- High Mechanical Efficiency Glass Fiber ERC 70 kN Core.
- Warranty: 15 Years.
- WEIGHT 1,4 Kg.



Cod.	Service Voltage	Creepage Dist.	Min. Protected Line	Mechanical Load	Test Voltages	
					1,2/50 BIL	50 Hz/WET
C2470EBA	U_r	<i>C.D.</i>	<i>Dry arc</i>	<i>SML</i>	kV	kV
Drawing	kV	mm	mm	kN	kV	kV
GN000021D	24	650	310	70	125	50

POLYMERIC CHAIN INSULATOR_FOR AERIAL LINES IN POLLUTION LEVEL e. 24 kV 70kN -
END FITTINGS EYE-BALL- REF. [ENDESA 6709639 / TAM 530699](#)

TECHNICAL DATA SHEET OF THE INSULATOR

REF.: 24/70 EB MA

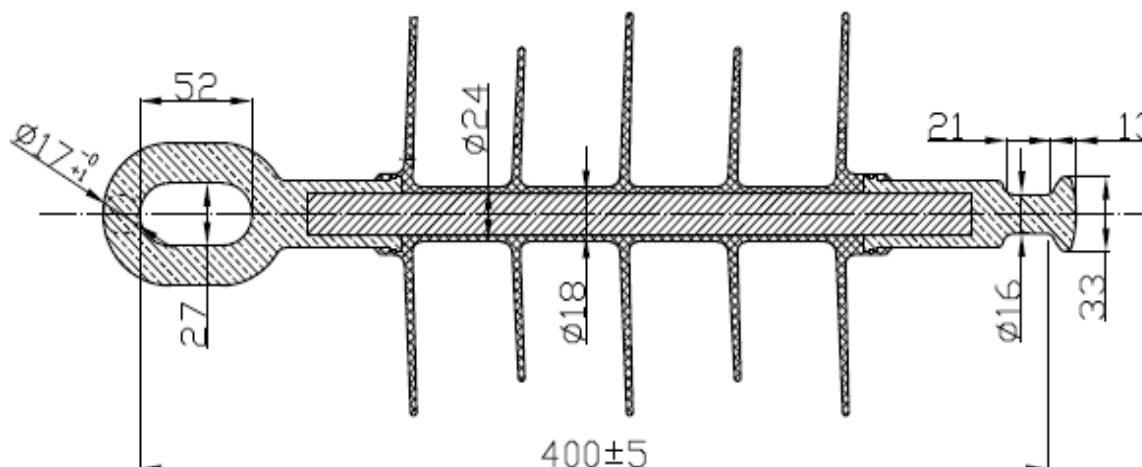

Main Characteristics:

- Recommended in Coastal Areas.
- Minimum protection 120 mm in Fittings.
- Better performance in Very High Pollution areas.
- Made of HTV Silicone.
- Hydrophobic Level Silicone HC2. Repels moisture accumulation.
- High Mechanical Efficiency Glass Fiber ERC 70 kN Core.
- Warranty: 15 Years. WEIGHT 1,5 Kg.

Cod.	Service Voltage	Creepage Dist.	Min. Protected Line	Mechanical Load	Test Voltages	
24/70EBMA	U_r	<i>C.D.</i>	<i>Dry arc</i>	<i>SML</i>	1,2/50 BIL	50 Hz/WET
Drawing	kV	mm	mm	kN	kV	kV
GN-0000654D	24	870	350	70	125	50



POLYMERIC CHAIN INSULATOR FOR AERIAL LINES IN HIGH POLLUTION LEVEL 25 kV 70kN_
END FITTINGS CLEVIS-TONGUE - REF. **IDISNORTE-DISSUR 458540**

TECHNICAL DATA SHEET OF THE INSULATOR
Mod. : C2570CT

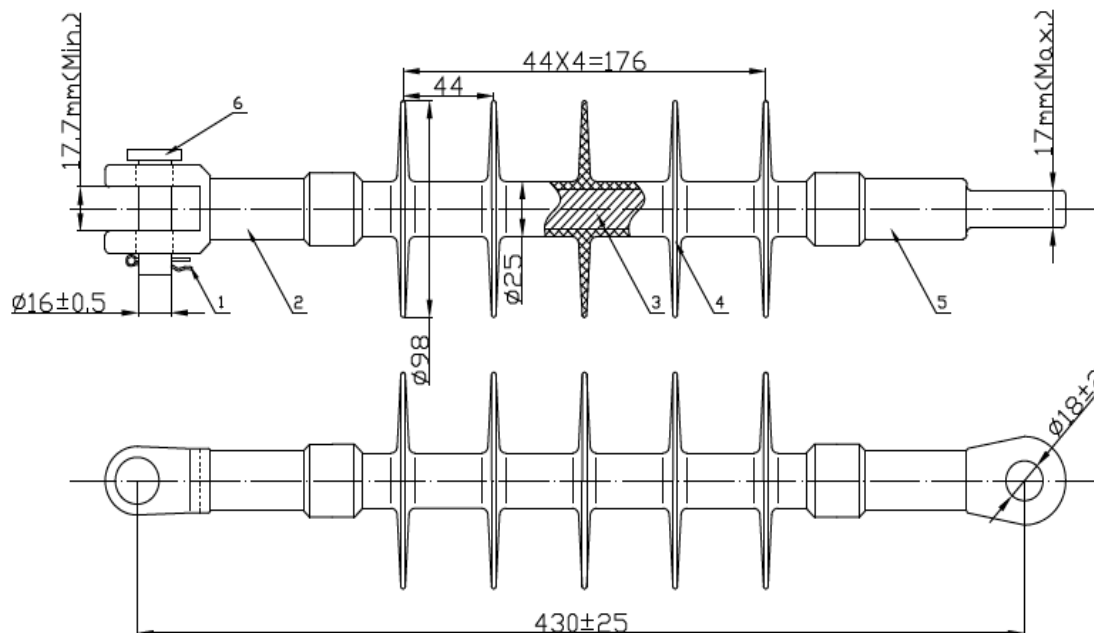

Main Characteristics:

- Suitable for High Pollution Areas. Warranty : 10 Years.
- Continuous HTV Silicone Coating. .
- Production center certified ISO9001 - ISO14001.
- Hydrophobic Level Silicone HC2. Repels moisture accumulation.
- Reinforced Resin Core with Glass Fiber (ECR) _ CME Routine 3500daN.
- Effective performance in high pollution areas.
- Hot-Dip Galvanized Fittings. HDG.

Cod.	Service Voltage	Creepage Dist.	Min. Protected Line	Mechanical Load	Test Voltages			
					POS.BIL	NEG.BIL	F.I./WET	F.I./DRY
C2570CT	kV	mm	mm	daN	kV	kV	kV	kV
Weight(kg)	25	550	290	7000	190	205	100	130

CHAIN INSULATORS



POLYMERIC CHAIN INSULATOR FOR AERIAL LINES IN POLLUTION LEVEL e. 30 kV 70kN _
END FITTINGS TONGUE-TONGUE – REF. **IBERDROLA** U70PP30P

TECHNICAL DATA SHEET OF THE INSULATOR

REF.: U70PP30P – CODE 4803212



Illustrative image of
a similar insulator.
Not representative.

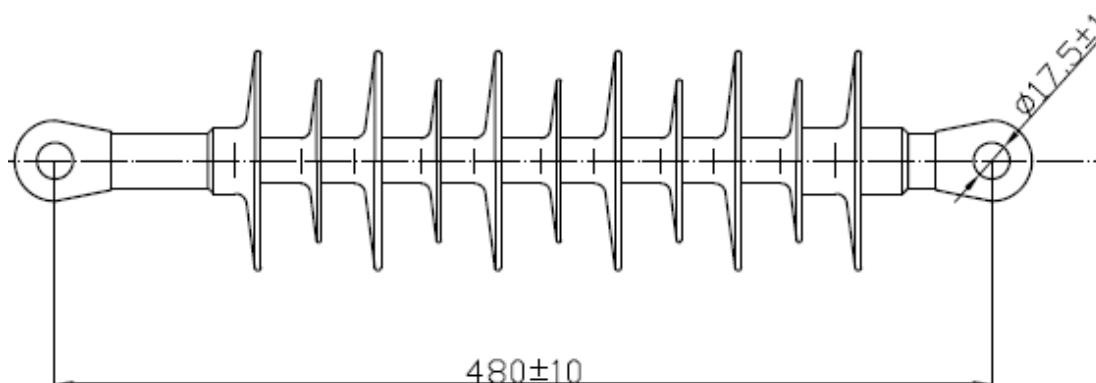

Main Characteristics:

- Single body insulator. Higher stiffness.
- Continuous HTV Silicone Coating.
- Hydrophobic Level Silicone HC2. Repels moisture accumulation.
- High Mechanical Efficiency Glass Fiber ERC 70 kN Core.
- Warranty: 15 Years.
- WEIGHT 2,5 Kg.

Cod.	Service Voltage	Creepage Dist.	Min. Protected Line	Mechanical Load	Test Voltages	
U70PP30P	U_r	<i>C.D.</i>	<i>Dry arc</i>	<i>SML</i>	1,2/50 BIL	50 Hz/WET
Drawing	kV	mm	mm	kN	kV	kV
GN0001698B	30	1120	310	70	215	95



POLYMERIC CHAIN INSULATOR FOR AERIAL LINES IN POLLUTION LEVEL d. 36 kV 70kN_ END FITTINGS EYE-BALL - REF. ENDESA 6702343 / TAM 300032

TECHNICAL DATA SHEET OF THE INSULATOR REF.: 36/70 EBA

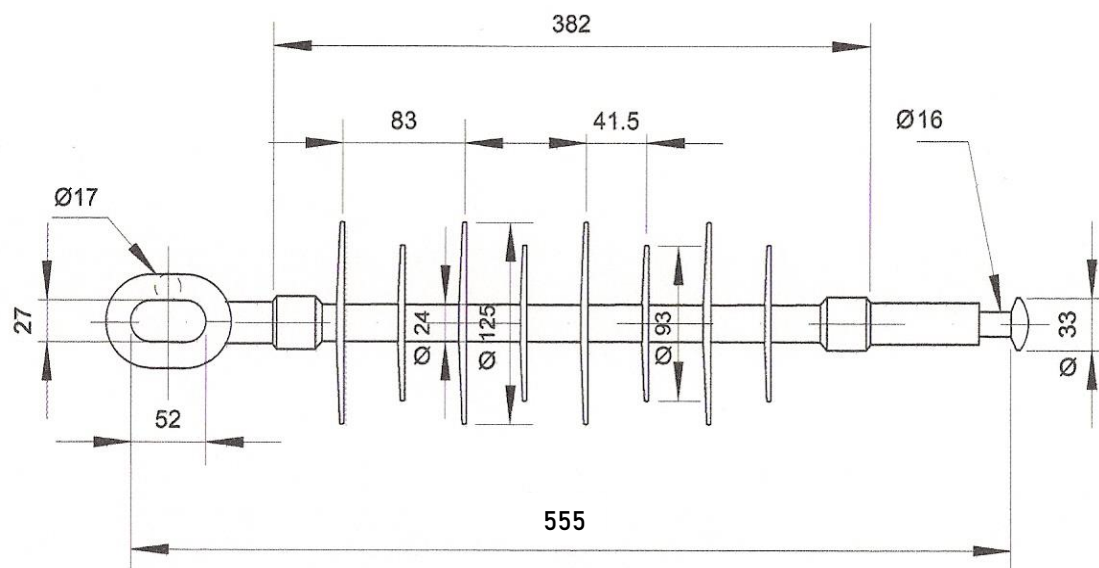

Main Characteristics:

- Single body insulator. Higher stiffness.
- Better performance in areas of medium pollution.
- Continuous HTV Silicone Coating.
- Hydrophobic Level Silicone HC2. Repels moisture accumulation.
- High Mechanical Efficiency Glass Fiber ERC 70 kN Core.
- Warranty: 15 Years. WEIGHT 1,7 Kg.



Cod.	Service Voltage	Creepage Dist.	Min. Protected Line	Mechanical Load	Test Voltages	
C3670EB	<i>Ur</i>	<i>C.D.</i>	<i>Dry arc</i>	<i>SML</i>	1,2/50 BIL	50 Hz/WET
Drawing	kV	mm	mm	kN	kV	kV
GN000022D	36	980	415	70	170	70

POLYMERIC CHAIN INSULATOR FOR AERIAL LINES IN POLLUTION LEVEL d. 36 kV 100kN_ END FITTINGS EYE-BALL

TECHNICAL DATA SHEET OF THE INSULATOR
REF.: 36/100 EBA

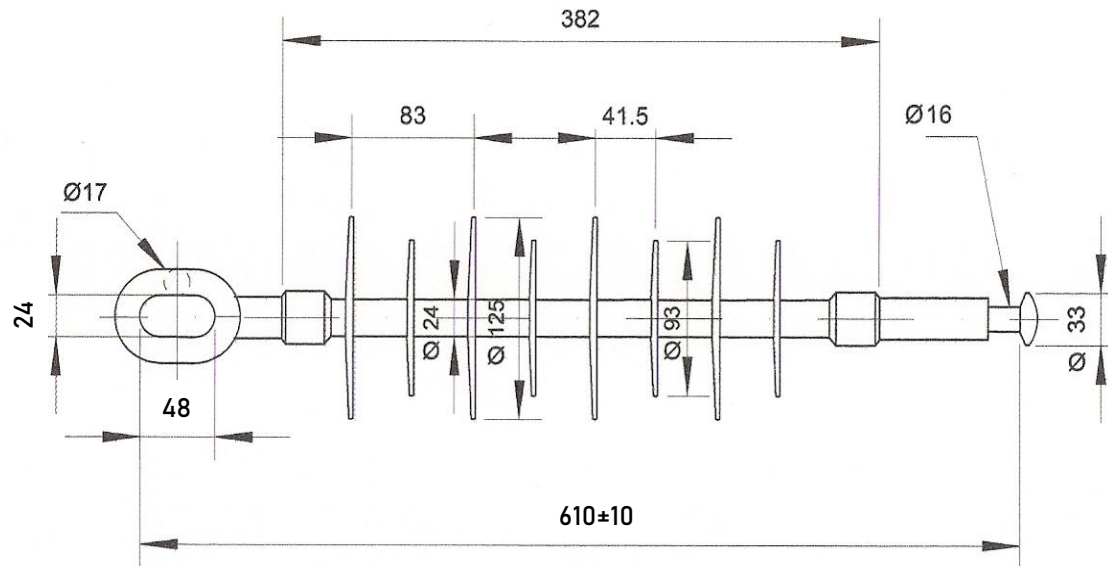

Main Characteristics:

- Single body insulator. Higher stiffness.
- Better performance in areas of medium pollution.
- Continuous HTV Silicone Coating.
- Hydrophobic Level Silicone HC2. Repels moisture accumulation.
- High Mechanical Efficiency Glass Fiber ERC Core 100 kN
- Warranty: 15 Years. WEIGHT 1,97 Kg.



Cod.	Service Voltage	Creepage Dist.	Min. Protected Line	Mechanical Load	Test Voltages	
C36100EB	<i>U_r</i>	<i>C.D.</i>	<i>Dry arc</i>	<i>SML</i>	1,2/50 BIL	50 Hz/WET
Drawing	kV	mm	mm	kN	kV	kV
GN000022G	36	980	415	100	200	80

CHAIN INSULATORS



POLYMERIC CHAIN INSULATOR FOR AERIAL LINES IN POLLUTION LEVEL *e* . 36 kV 70kN _ END FITTINGS EYE-BALL - **ANTIDROPPINGS.**

Main Characteristics.

- 1st Dielectric Function Fin + Antidroppings Protection.
- Single body insulator. Higher stiffness.
- Better performance in high pollution areas: Pollution level "e".
- Continuous HTV Silicone Coating.
- Hydrophobic Level Silicone HC2. Repels moisture accumulation.
- High Mechanical Efficiency Glass Fiber ERC 70 kN Core.
- WEIGHT 1,89 Kg.

-The CAD36EADPGS chain provides a distance greater than 0.75 m from the conductor to the anchor shackle at the crossarm, as required by current regulations for Suspension/Alignment Chains.



DATA SHEET - INSULATOR C3670EB_AD

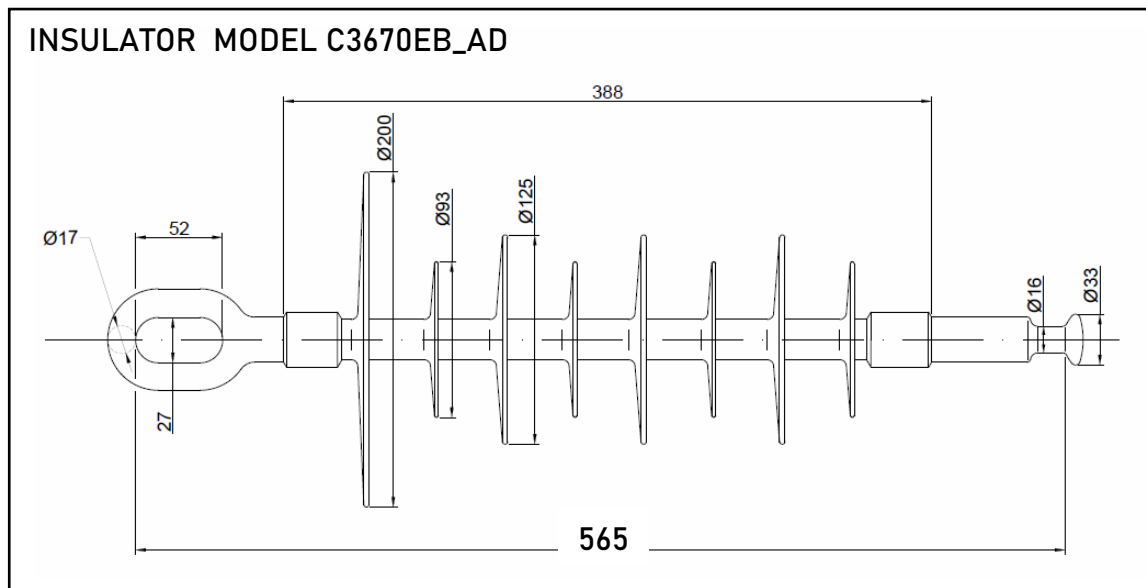

SURFACE AREA OF CHAINS m² FOR WIND RESISTANCE CALCULATIONS

CHAIN SUSPENSION LA-56 (GS-1)	0,0316m ²
CHAIN SUSPENSION LA-110 (GS-2)	0,0317m ²

Cod.	Service Voltage	Creepage Dist.	Min.Protect. Line	Mechanical Load	Test Voltages	
	<i>Ur</i>	<i>C.D.</i>	<i>Dry Arc</i>	<i>SML</i>	1,2/50 BIL	50 Hz/Rain
Drawing	kV	mm	mm	kN	kV	kV
C3670EB-AD	36	1150	415	70	170	70

CHAIN INSULATORS WITH ANTIDROPPINGS SYSTEM



DIMENSIONS OF ASSEMBLED POLYMERIC CHAINS

Dimensions of 24 kV Assembled Polymeric Chain

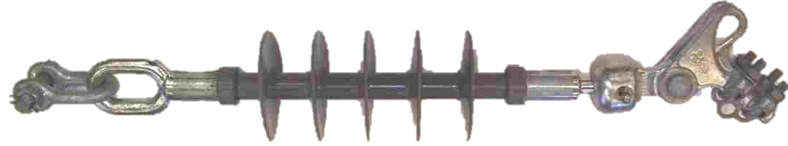
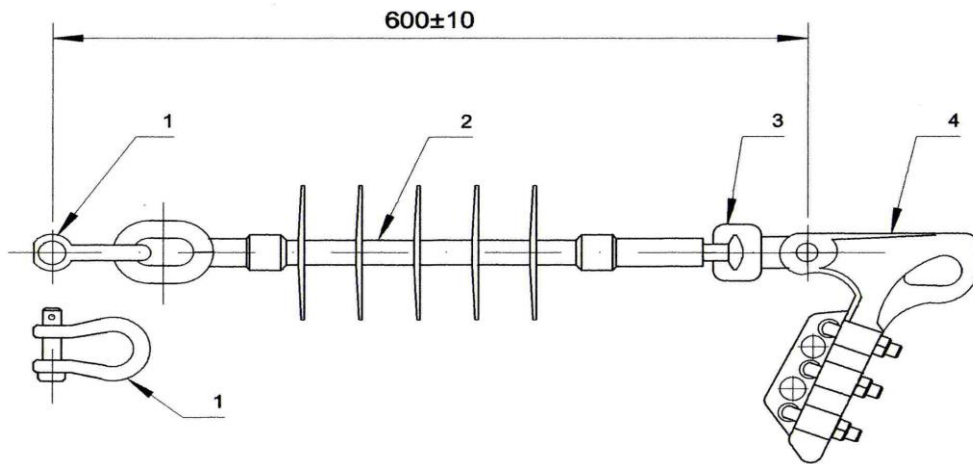

PHOTO: EXAMPLE OF 24 KV 70 KN ANCHOR CHAIN - WEIGHT: 2.75 kg



DENOMINATION	DESCRIPTION
1	GN CONNECTOR
2	POLYMERIC INSULATOR
3	SHORT JOINT
4	CLAMP

Dimensions of 36 kV Assembled Polymeric Chain

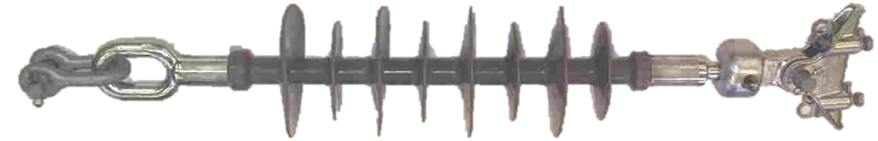
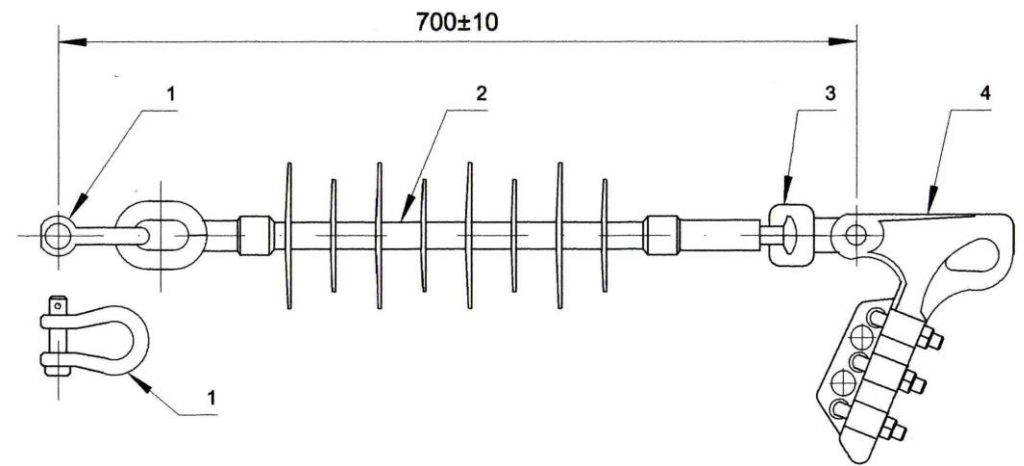

PHOTO: EXAMPLE OF 36 KV 70 KN SUSPENSION CHAIN - WEIGHT: 3.07 kg



DENOMINATION	DESCRIPTION
1	GN CONNECTOR
2	POLYMERIC INSULATOR
3	SHORT JOINT
4	CLAMP

DATA SHEET

COMPLETE CHAIN DIMENSIONS

CHAIN INSULATORS



POLYMERIC CHAIN INSULATOR FOR AERIAL LINES AT POLLUTION LEVEL e. 30 kV 70 kN_ END FITTINGS EYE-BALL - REF. **IBERDROLA** U70AB30P

TECHNICAL DATA SHEET OF THE INSULATOR

REF.: U70AB30P - CODE 4803211



Illustrative image, not representative. It may not correspond to the presented insulator.

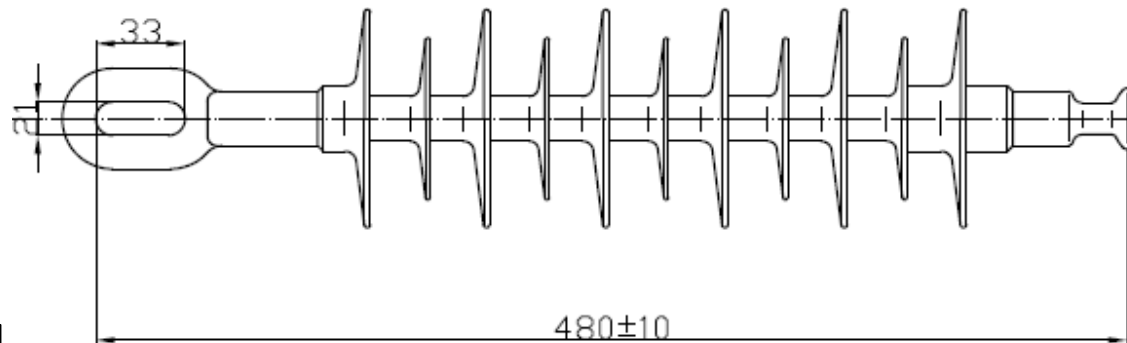

Main Characteristics:

- Single body insulator. Higher stiffness.
- Continuous HTV Silicone Coating.
- Hydrophobic Level Silicone HC2. Repels moisture accumulation.
- High Mechanical Efficiency Glass Fiber ERC 70 kN Core.
- Warranty: 15 Years.
- WEIGHT 2,5 Kg.

Cod.	Service Voltage	Creepage Dist.	Min. Protected Line	Mechanical Load	Test Voltages	
U70AB30P	U_r	$C.D.$	$Dry\ arc$	SML	1,2/50 BIL	50 Hz/WET
Drawing	kV	mm	mm	kN	kV	kV
GN0001699B	30	1120	310	70	215	95



POLYMERIC CHAIN INSULATOR FOR AERIAL LINES AT POLLUTION LEVEL *d* . 36 kV IEC STANDARD-61109:2008_ END FITTINGS SOCKET - BALL

TECHNICAL DATA SHEET OF THE INSULATOR

REF.: 36/120SB_900

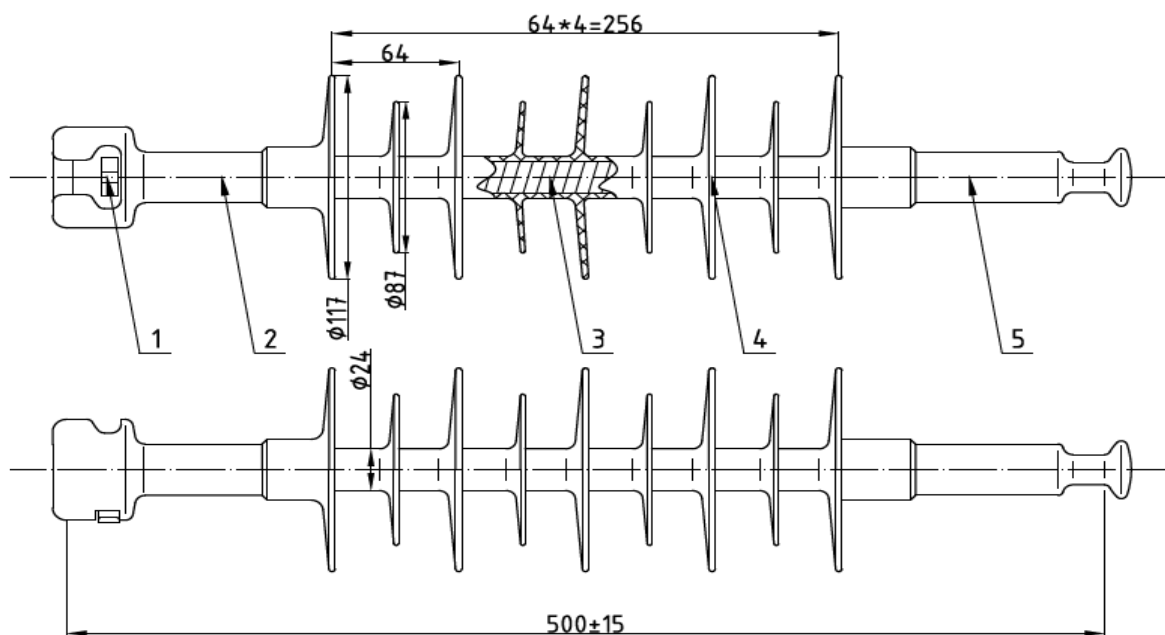

Main Characteristics:

- Single body insulator. Higher stiffness.
- Continuous HTV Silicone Coating.
- Hydrophobic Level Silicone HC2. Repels moisture accumulation.
- High Mechanical Efficiency Glass Fiber ERC Core 120 KN.
- Warranty: 15 Years.
- WEIGHT 1,8 Kg.

Cod.	Service Voltage	Creepage Dist.	Min. Protected Line	Mechanical Load	Test Voltages	
C36120_SB_900	<i>Ur</i>	<i>C.D.</i>	<i>Dry arc</i>	<i>SML</i>	1,2/50 BIL	50 Hz/WET
Drawing	kV	mm	mm	kN	kV	kV
GN0002163A	36	900	350	120	170	70



POLYMERIC CHAIN INSULATOR FOR AERIAL LINES AT POLLUTION LEVEL *e* . 36 kV STANDARD IEC-61109:2008 _ END FITTINGS SOCKET - BALL

TECHNICAL DATA SHEET OF THE INSULATOR

REF.: 36/80SB_1200

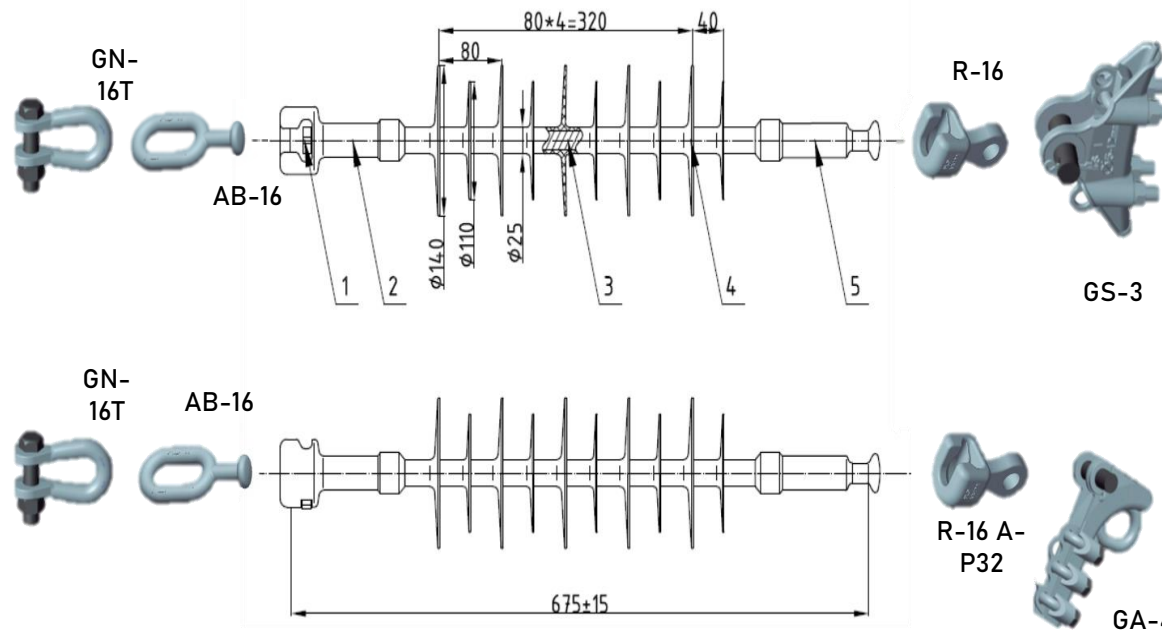

Main Characteristics:

- Single body insulator. Higher stiffness.
- Recommended in Coastal Areas.
- Better performance in areas of high contamination.
- Continuous HTV Silicone Coating.
- Hydrophobic Level Silicone HC2. Repels moisture accumulation.
- High Mechanical Efficiency Glass Fiber ERC Core 80 KN.
- Warranty: 15 Years.
- WEIGHT 1,9 Kg.

Cod.	Service Voltage	Creepage Dist.	Min. Protected Line	Mechanical Load	Test Voltages	
					1,2/50 BIL	50 Hz/WET
C3680_SB_1200	<i>Ur</i>	<i>C.D.</i>	<i>Dry arc</i>	<i>SML</i>	kV	kV
Drawing	kV	mm	mm	kN	kV	kV
GN0002169A	36	1200	430	80	290	145

CHAIN INSULATORS



POLYMERIC CHAIN INSULATOR FOR AERIAL LINES AT POLLUTION LEVEL *e* .
45 kV 70kN _ END FITTINGS EYE-BALL - REF. **IBERDROLA** U70AB45P

TECHNICAL DATA SHEET OF THE INSULATOR

REF.: U70AB45P - CODE 4803216

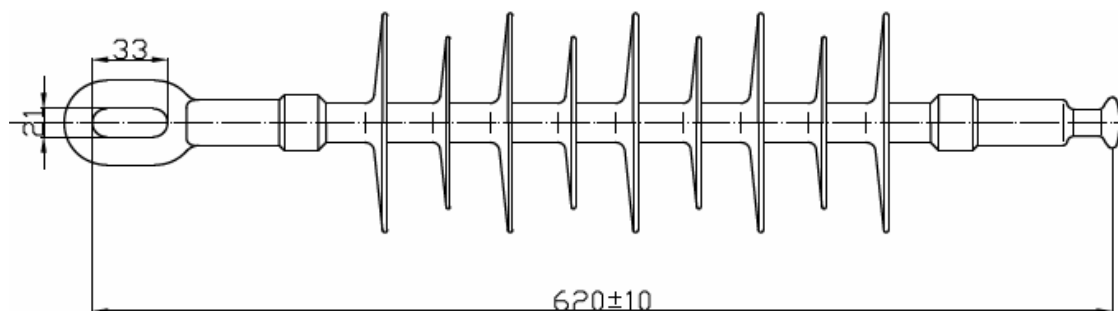

Main Characteristics:

- Single body insulator. Higher stiffness.
- Continuous HTV Silicone Coating.
- Hydrophobic Level Silicone HC2. Repels moisture accumulation.
- High Mechanical Efficiency Glass Fiber ERC 70 kN Core.
- Warranty: 15 Years.
- WEIGHT 3,3 Kg.

Cod.	Service Voltage	Creepage Dist.	Min. Protected Line	Mechanical Load	Test Voltages	
U70AB45P	<i>Ur</i>	<i>C.D.</i>	<i>Dry arc</i>	<i>SML</i>	1,2/50 BIL	50 Hz/WET
Drawing	kV	mm	mm	kN	kV	kV
GN0001700B	45	1610	450	70	300	120



POLYMERIC CHAIN INSULATOR FOR AERIAL LINES AT POLLUTION LEVEL *e* . 66 kV 70kN _ END FITTINGS EYE-BALL - REF. **IBERDROLA** U70AB66P

TECHNICAL DATA SHEET OF THE INSULATOR

REF.: U70AB66P - CODE 4803221

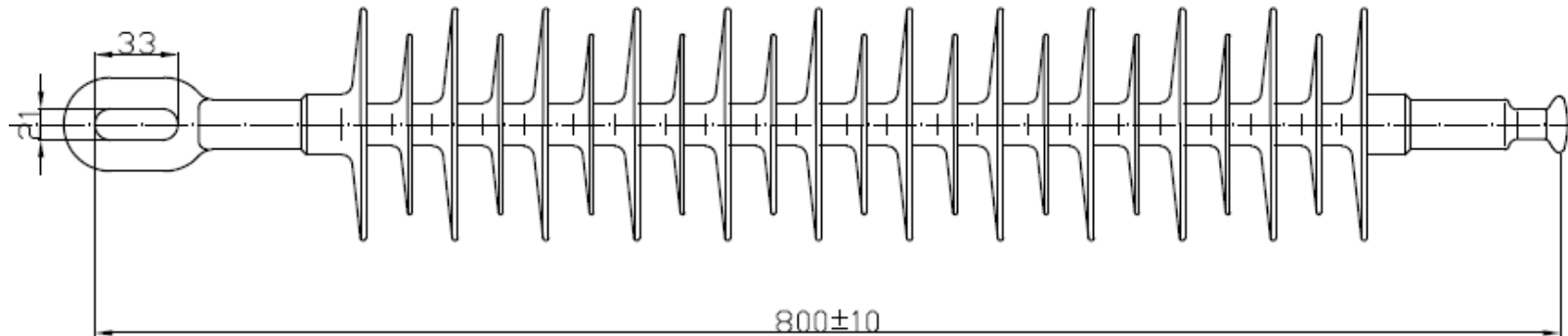

Main Characteristics:

- Single body insulator. Higher stiffness.
- Continuous HTV Silicone Coating.
- Hydrophobic Level Silicone HC2. Repels moisture accumulation.
- High Mechanical Efficiency Glass Fiber ERC 70 kN Core.
- Warranty: 15 Years. WEIGHT 4,00 Kg.

Illustrative image, not representative. It may not correspond to the presented insulator.

Cod.	Service Voltage	Creepage Dist.	Min. Protected Line	Mechanical Load	Test Voltages	
U70AB66P	<i>U_r</i>	<i>C.D.</i>	<i>Dry arc</i>	<i>SML</i>	1,2/50 BIL	50 Hz/WET
Drawing	kV	mm	mm	kN	kV	kV
GN0001702B	66	2250	590	70	380	165



POLYMERIC CHAIN INSULATOR FOR AERIAL LINES AT POLLUTION LEVEL *e* .
66 kV 100kN – END FITTINGS SOCKET-BALL – REF. **ENDESA** 6708829

**POLYMERIC CHAIN INSULATOR FOR 66/72.5 kV
AERIAL LINES 100 kN**

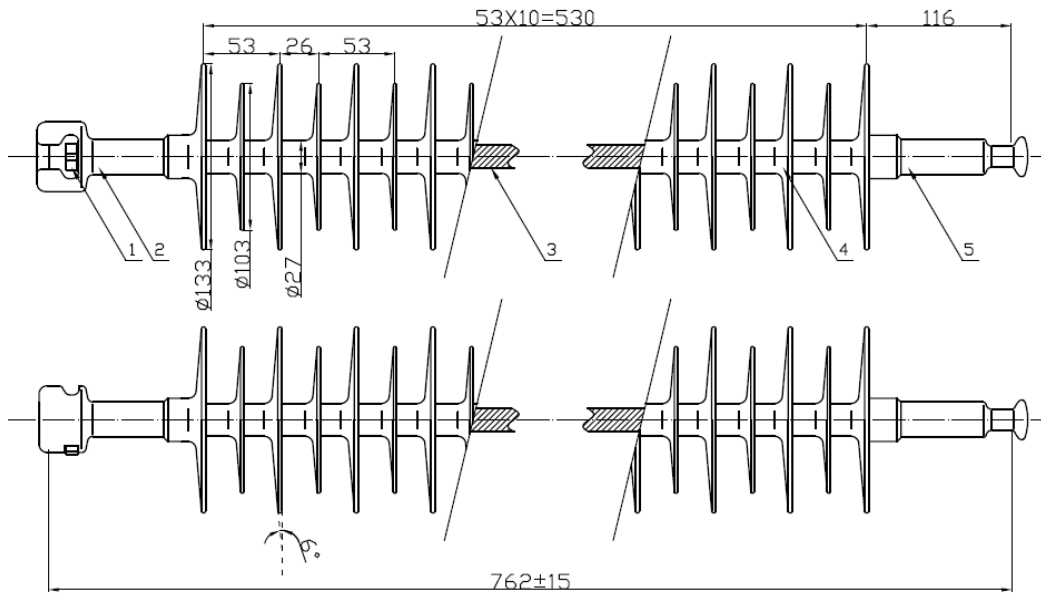

Main Characteristics:

- Insulator Weight: 2.8 kg
- Suitable for Very High Contamination Areas. Warranty: 15 Years.
- Continuous HTV Silicone Coating.
- Hydrophobic Level Silicone HC2. Repels moisture accumulation.
- High Mechanical Efficiency Glass Fiber ERC Core 100 kN.
- Better performance in areas of high contamination.
- L = Total Length of Mounted Anchor Chain = 1,060 mm +/- 15 mm.

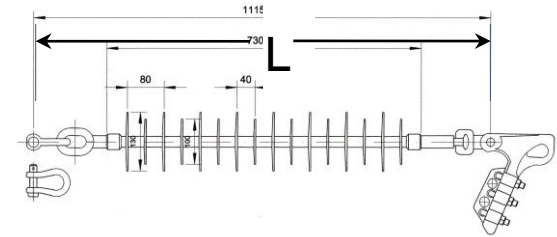

Cod.	Service Voltage	Creepage Dist.	Min. Protected Line	Mechanical Load	Test Voltages	
C66100SB_E	<i>U_r</i>	<i>C.D.</i>	<i>Dry arc</i>	<i>SML</i>	1,2/50 BIL	50 Hz/WET
Drawing	kV	mm	mm	kN	kV	kV
GN0001231D	66/72,5	2250	570	100	325	140

CHAIN INSULATORS



POLYMERIC CHAIN INSULATOR FOR AERIAL LINES AT POLLUTION LEVEL e . 66kV 120kN _
END FITTINGS EYE-BALL - **BIRD PROTECTION USE. ISOLATED LENGTH ≥ 1.025 m**

TECHNICAL DATA SHEET OF THE INSULATOR
REF.: C66120EB/1025



Illustrative image, not representative. It may not correspond to the presented insulator.

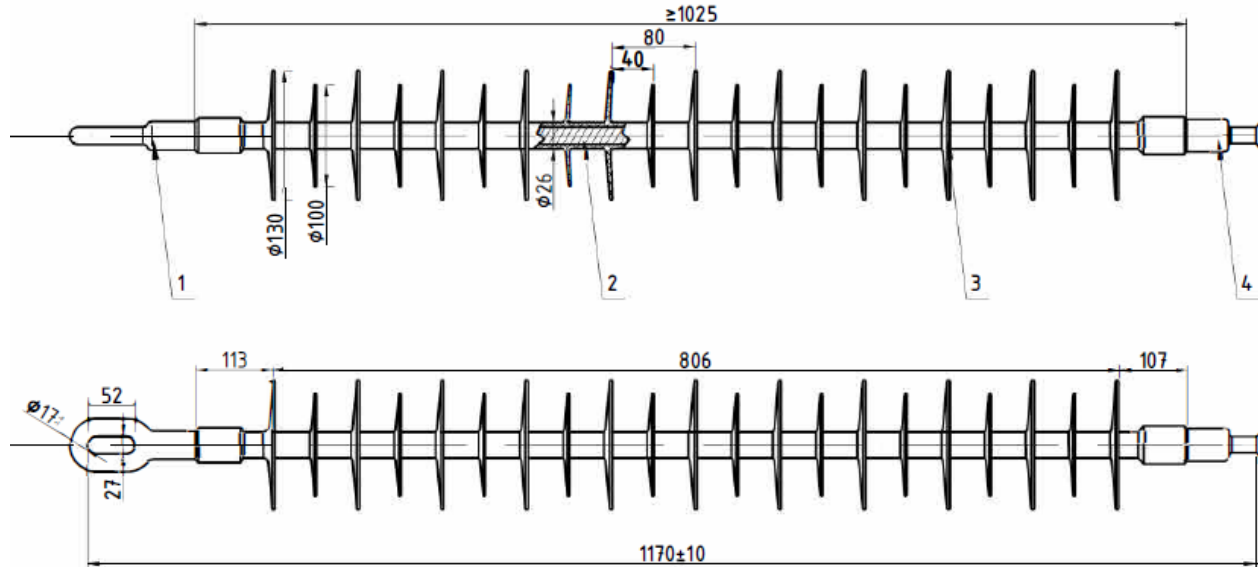

Main Characteristics:

- Single body insulator. Higher stiffness.
- Continuous HTV Silicone Coating.
- Hydrophobic Level Silicone HC2. Repels moisture accumulation.
- High Mechanical Efficiency Glass Fiber ERC Core 120 KN.
- Warranty: 15 Years. WEIGHT 3,4 Kg.



Cod.	Service Voltage	Creepage Dist.	Min. Protected Line	Mechanical Load	Test Voltages	
C66120EB/1025	<i>Ur</i>	<i>C.D.</i>	<i>Dry arc</i>	<i>SML</i>	1,2/50 BIL	50 Hz/WET
Drawing	kV	mm	mm	kN	kV	kV
GN0002557C	66	2250	1025	120	380	165

CHAIN INSULATORS - BIRD PROTECTION USE - CHAIN >1m



POLYMERIC CHAIN INSULATOR FOR 69 kV AERIAL LINES STANDARD IEC 61109 - END FITTINGS SOCKET/BALL

**POLYMERIC CHAIN
INSULATOR FOR 69 kV
AERIAL LINES 120 Kn**

DATA SHEET CODE ETED: DMI-GMR-060

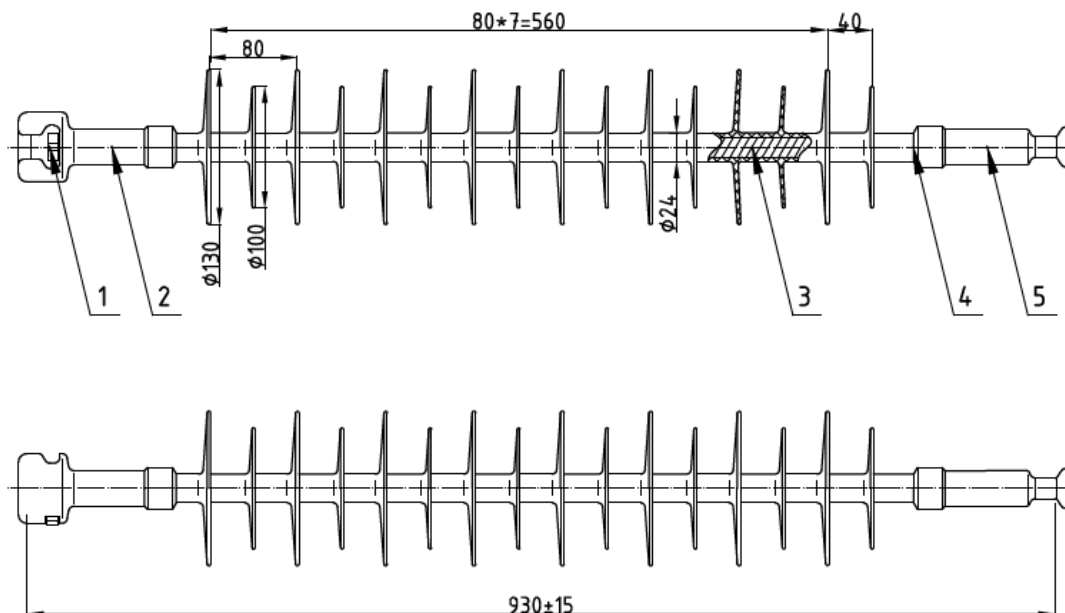

Main Characteristics:

- Continuous HTV Silicone Coating. .
- Hydrophobic Level Silicone HC2. Repels moisture accumulation.
- High Mechanical Efficiency Glass Fiber ERC Core 120 kN

Cod.	Service Voltage	Creepage Dist.	Min. Protected Line	Mechanical Load	Test Voltages	
C69120SB	<i>U_r</i>	<i>C.D.</i>	<i>Dry arc</i>	<i>SML</i>	1,2/50 BIL	60 Hz/WET
Drawing	kV	mm	mm	kN	kV	kV
GN0002623A	69	1800	700	120	480	140



POLYMERIC CHAIN INSULATOR FOR 69 kV AERIAL LINES STANDARD IEC 61109 - END FITTINGS SOCKET/BALL

**POLYMERIC CHAIN
INSULATOR FOR 69 kV
AERIAL LINES 66 Kn**

DATA SHEET CODE ETED: DMI-GMR-061

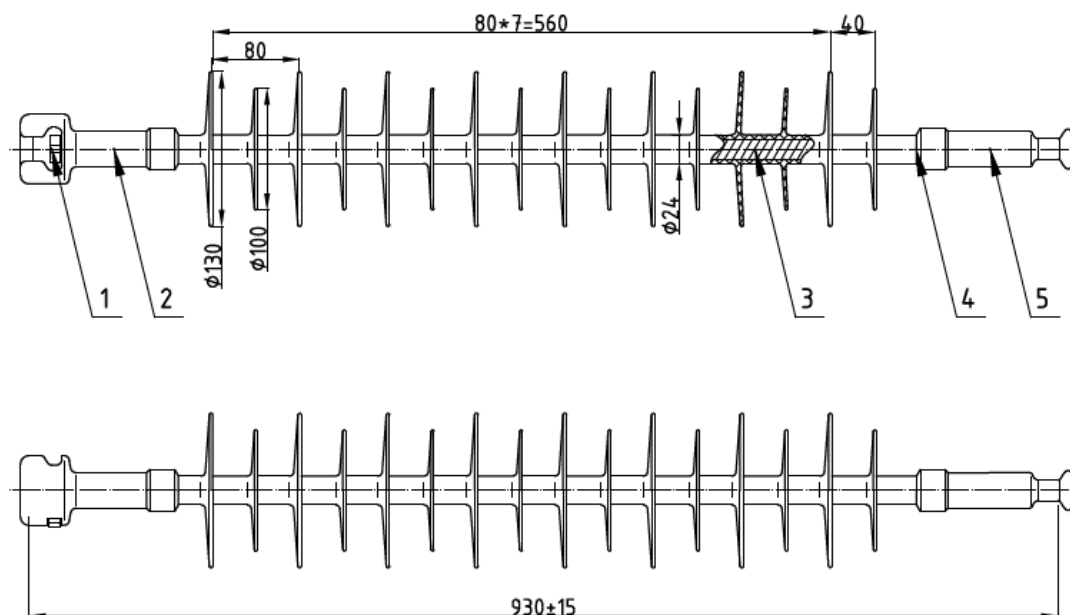

Main Characteristics:

- Continuous HTV Silicone Coating. .
- Hydrophobic Level Silicone HC2. Repels moisture accumulation.
- High Mechanical Efficiency Glass Fiber ERC Core 66 kN

Cod.	Service Voltage	Creepage Dist.	Min. Protected Line	Mechanical Load	Test Voltages	
C6966SB	<i>U_r</i>	<i>C.D.</i>	<i>Dry arc</i>	<i>SML</i>	1,2/50 BIL	60 Hz/WET
Drawing	kV	mm	mm	kN	kV	kV
GN0002624A	69	1800	700	66	480	140



POLYMERIC CHAIN INSULATOR FOR AERIAL LINES AT POLLUTION LEVEL *e* .
66 kV 100kN - END FITTINGS Y-CLEVIS-CLEVIS - REF. **ENDESA 6708825**

**POLYMERIC CHAIN INSULATOR
FOR AERIAL LINES
66/72.5 kV 100 kN**

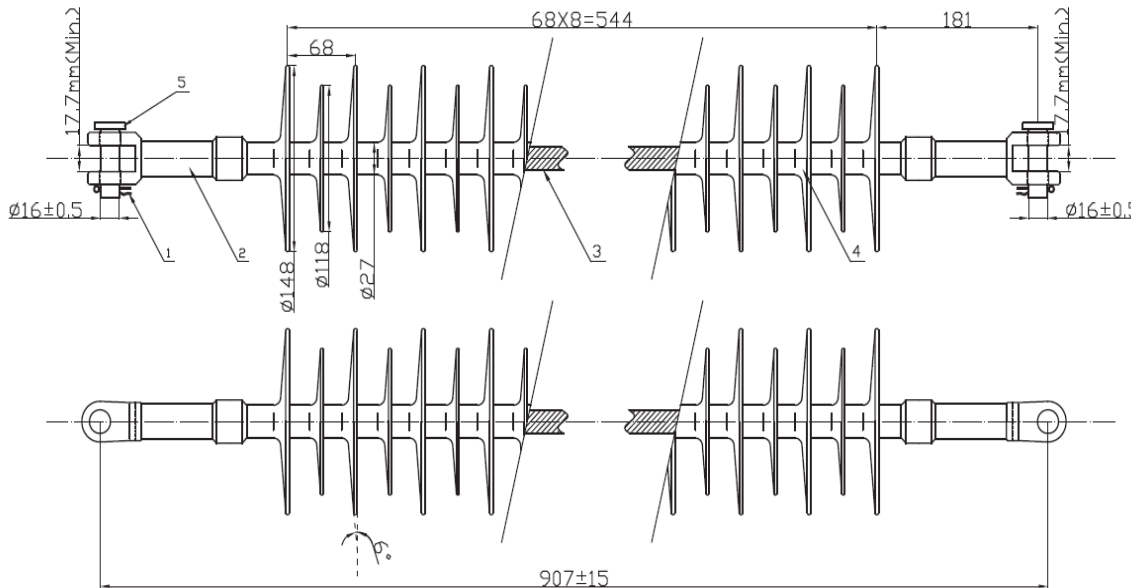

Main Characteristics:

- Insulator Weight : 3,2 Kg
- Suitable for Very High Contamination Areas.
- Warranty : 15 Years.
- Continuous HTV Silicone Coating. .
- Hydrophobic Level Silicone HC2. Repels moisture accumulation.
- High Mechanical Efficiency Glass Fiber ERC Core 100 kN
- Better performance in areas of high contamination.

Cod.	Service Voltage	Creepage Dist.	Min. Protected Line	Mechanical Load	Test Voltages	
					1,2/50 BIL	50 Hz/WET
C66100CC_E	<i>Ur</i>	<i>C.D.</i>	<i>Dry arc</i>	<i>SML</i>	kV	kV
Drawing	kV	mm	mm	kN	kV	kV
GN0001249D	66/72,5	2250	570	100	325	140

CHAIN INSULATORS



POLYMERIC CHAIN INSULATOR FOR AERIAL LINES AT POLLUTION LEVEL *e* .
132kV 120kN _ END FITTINGS EYE-BALL - REF. **IBERDROLA** U120AB132P

TECHNICAL DATA SHEET OF THE INSULATOR
REF.: U120AB132P - CODE 4803251

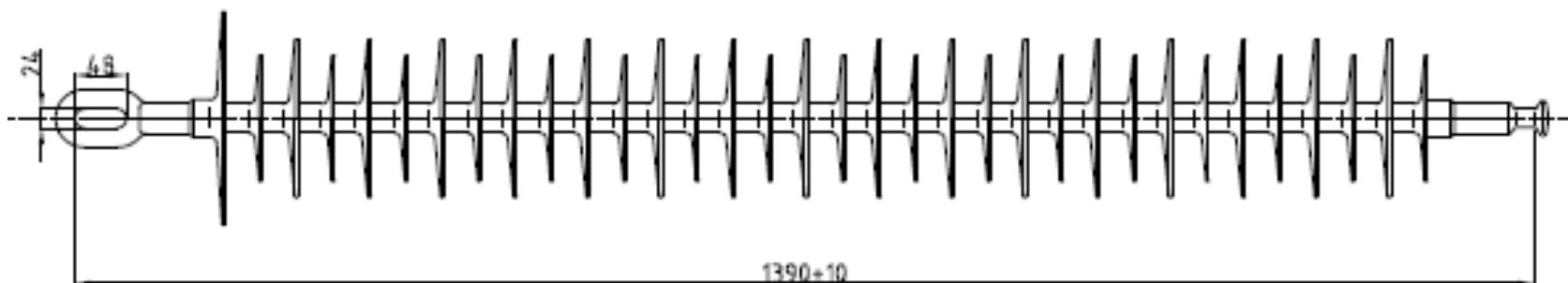

Main Characteristics:

- Single body insulator. Higher stiffness.
- Continuous HTV Silicone Coating.
- Hydrophobic Level Silicone HC2. Repels moisture accumulation.
- High Mechanical Efficiency Glass Fiber ERC Core 120 KN.
- Warranty: 15 Years. WEIGHT 7,0 Kg.

Cod.	Service Voltage	Creepage Dist.	Min. Protected Line	Mechanical Load	Test Voltages	
U120AB132P	<i>U_r</i>	<i>C.D.</i>	<i>Dry arc</i>	<i>SML</i>	1,2/50 BIL	50 Hz/WET
Drawing	kV	mm	mm	kN	kV	kV
GN0001707B	132	4500	1130	120	650	320

CHAIN INSULATORS



POLYMERIC CHAIN INSULATOR FOR AERIAL LINES AT POLLUTION LEVEL *e* .
132kV 120kN _ END FITTINGS EYE-BALL – REF. **VIESGO** C132120EBA

TECHNICAL DATA SHEET OF THE INSULATOR
REF.: C132120EBA



Main Characteristics:

- Single body insulator. Higher stiffness.
- Continuous HTV Silicone Coating.
- Hydrophobic Level Silicone HC2. Repels moisture accumulation.
- High Mechanical Efficiency Glass Fiber ERC Core 120 KN.
- Warranty: 15 Years. WEIGHT 7,0 Kg.

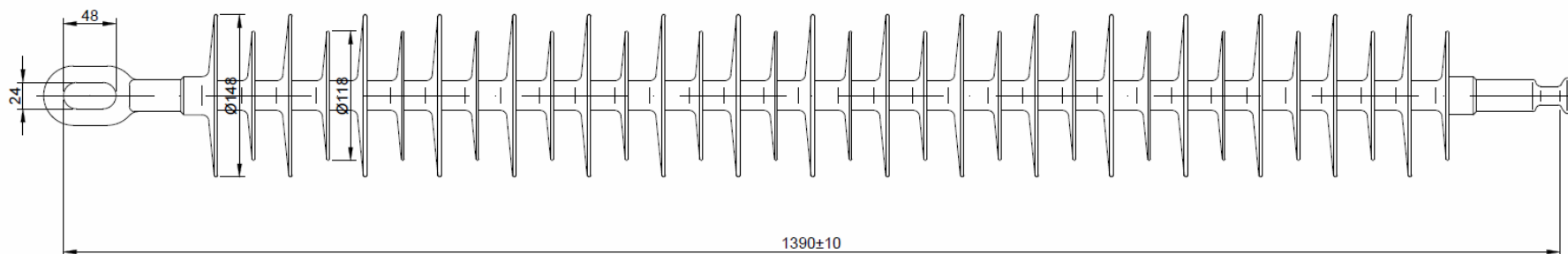

Cod.	Service Voltage	Creepage Dist.	Min. Protected Line	Mechanical Load	Test Voltages	
C132120EB	<i>Ur</i>	<i>C.D.</i>	<i>Dry arc</i>	<i>SML</i>	1,2/50 BIL	50 Hz/WET
Drawing	kV	mm	mm	kN	kV	kV
EN-C132120EBA	132	4500	1200	120	675	320

CHAIN INSULATORS



POLYMERIC CHAIN INSULATOR FOR AERIAL LINES AT POLLUTION LEVEL *e* .
132kV 120kN _ END FITTINGS EYE-BALL - **ANTIDROPPINGS** - REF. C132120EB_AD



TECHNICAL DATA SHEET OF THE INSULATOR
REF.: C132120EB_AD



Main Characteristics:

- Single body insulator. Higher stiffness.
- Continuous HTV Silicone Coating.
- Hydrophobic Level Silicone HC2. Repels moisture accumulation.
- High Mechanical Efficiency Glass Fiber ERC Core 120 KN.
- Warranty: 15 Years. WEIGHT 7,2 Kg.

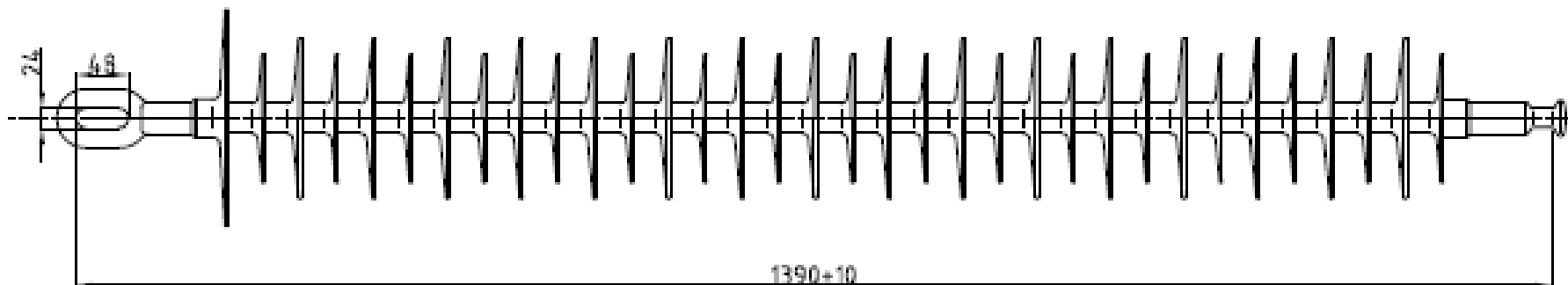

Cod.	Service Voltage	Creepage Dist.	Min. Protected Line	Mechanical Load	Test Voltages	
C132120EB_AD	<i>Ur</i>	<i>C.D.</i>	<i>Dry arc</i>	<i>SML</i>	1,2/50 BIL	50 Hz/WET
Drawing	kV	mm	mm	kN	kV	kV
EN-C132120EB_AD	132	4500	1200	120	675	320

CHAIN INSULATORS WITH ANTIDROPPINGS SYSTEM



POLYMERIC CHAIN INSULATOR FOR AERIAL LINES AT POLLUTION LEVEL *e* .
132 kV 100kN - END FITTINGS SOCKET/BALL - REF. **ENDESA** 6708831

**POLYMERIC CHAIN INSULATOR
FOR AERIAL LINES
132 kV 100 kN**

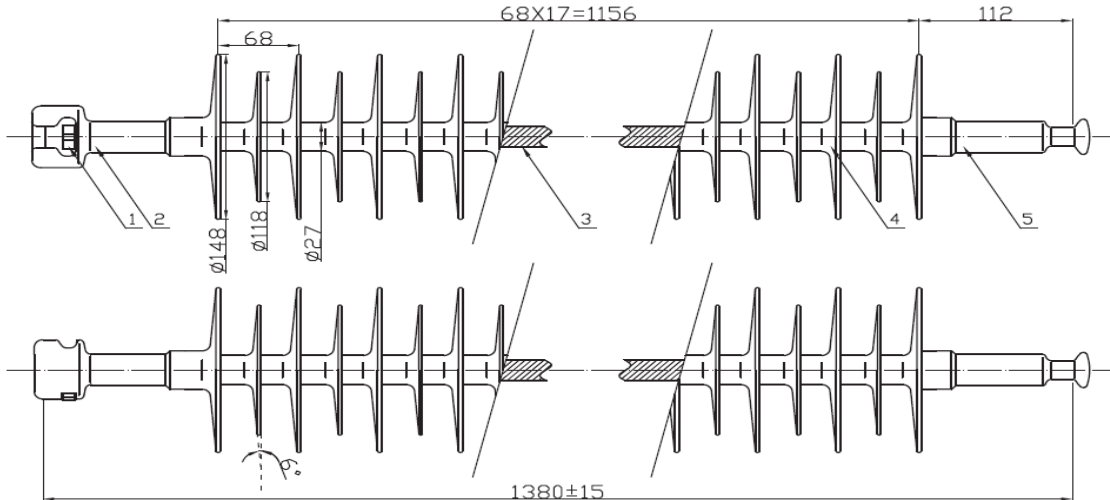

Main Characteristics:

- Insulator Weight : 5,75 Kg
- Suitable for Very High Contamination Areas. Warranty : 15 Years.
- Continuous HTV Silicone Coating. .
- Hydrophobic Level Silicone HC2. Repels moisture accumulation.
- High Mechanical Efficiency Glass Fiber ERC Core 100 kN
- Better performance in high pollution areas.
- L= Longitud total de Anchor Chain montada = 1.600mm +/- 15mm

Cod.	Service Voltage	Creepage Dist.	Min. Protected Line	Mechanical Load	Test Voltages	
C132100SB_E	<i>U_r</i>	<i>C.D.</i>	<i>Dry arc</i>	<i>SML</i>	1,2/50 BIL	50 Hz/WET
Drawing	kV	mm	mm	kN	kV	kV
GN0001247D	110/132	4500	1200	120	675	320

CHAIN INSULATORS



POLYMERIC CHAIN INSULATOR FOR AERIAL LINES AT POLLUTION LEVEL *e* .
132 kV 100kN - END FITTINGS Y-CLEVIS-CLEVIS - REF. **ENDESA 6708827**

POLYMERIC CHAIN INSULATOR FOR OVERHEAD LINES OF 110/132 kV 100 kN

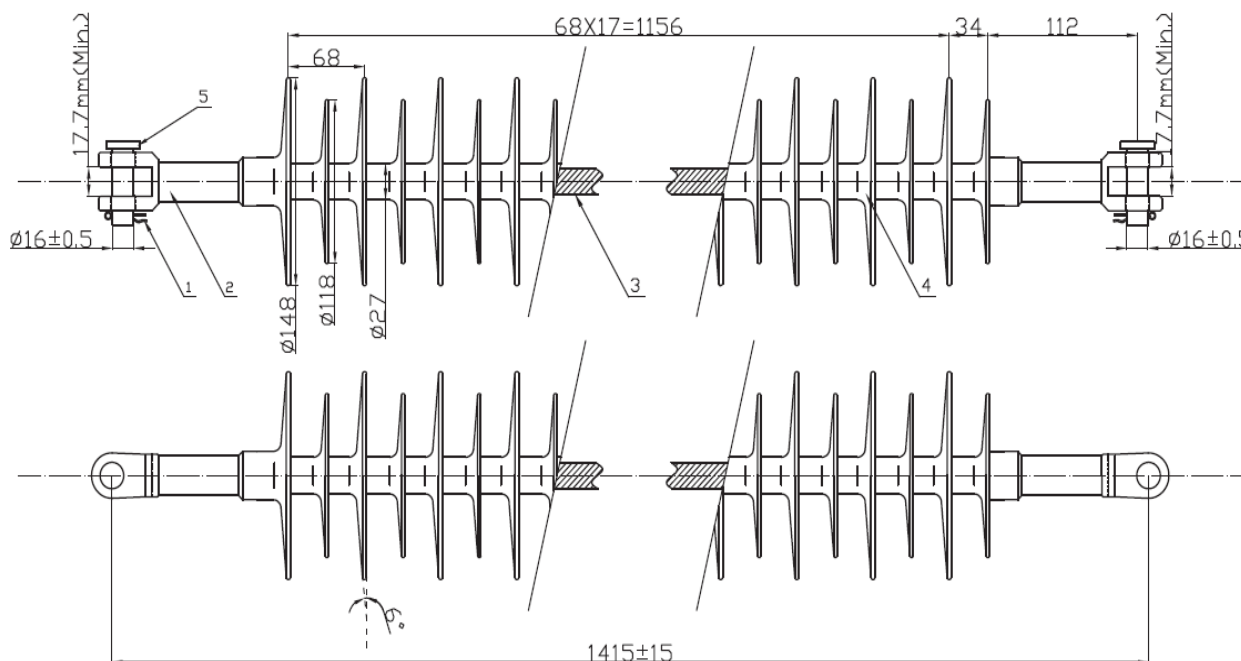

Main Characteristics:

- Insulator Weight : ,5,75 Kg
- Suitable for Very High Contamination Areas. Warranty : 15 Years.
- Continuous HTV Silicone Coating .
- Hydrophobic Level Silicone HC2. Repels moisture accumulation.
- High Mechanical Efficiency Glass Fiber ERC Core 100 kN
- Better performance in areas of high contamination.

Cod.	Service Voltage	Creepage Dist.	Min. Protected Line	Mechanical Load	Test Voltages	
C132100CC_E	<i>Ur</i>	<i>C.D.</i>	<i>Dry arc</i>	<i>SML</i>	1,2/50 BIL	50 Hz/WET
Drawing	kV	mm	mm	kN	kV	kV
GN0001248D	110/132	4500	1195	100	650	275



POLYMERIC CHAIN INSULATOR FOR AERIAL LINES AT POLLUTION LEVEL *d*.
132 kV 120kN _ END FITTINGS SOCKET-BALL - REF. **IBERDROLA** U120RB132

TECHNICAL DATA SHEET OF THE INSULATOR

REF.: U120RB132 - CODE 4803052



Main Characteristics:

- Single body insulator. Higher stiffness.
- Continuous HTV Silicone Coating.
- Hydrophobic Level Silicone HC2. Repels moisture accumulation.
- High Mechanical Efficiency Glass Fiber ERC Core 120 KN.
- Warranty: 15 Years. WEIGHT 5,0 Kg.

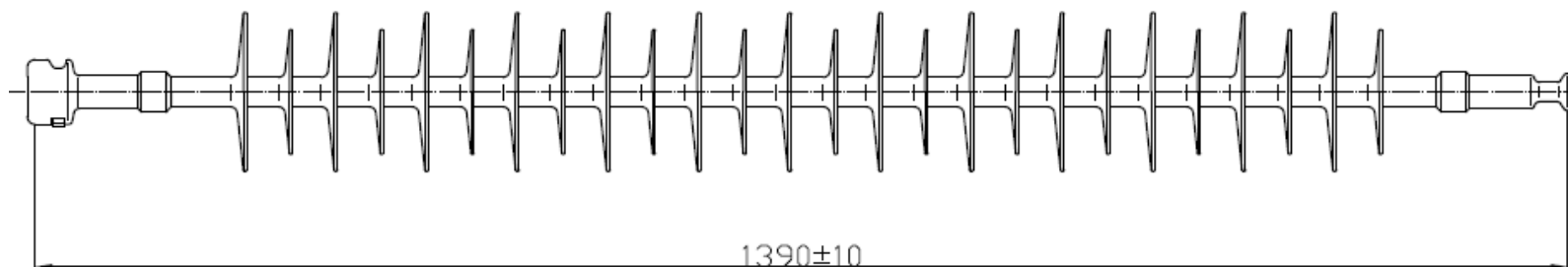

Cod.	Service Voltage	Creepage Dist.	Min. Protected Line	Mechanical Load	Test Voltages	
U120RB132	<i>U_r</i>	<i>C.D.</i>	<i>Dry arc</i>	<i>SML</i>	1,2/50 BIL	50 Hz/WET
Drawing	kV	mm	mm	kN	kV	kV
GN0001705B	132	2900	1080	120	650	275



POLYMERIC CHAIN INSULATOR FOR OVERHEAD LINES OF 138 kV IEC 61109 STANDARD – END FITTINGS SOCKET-BALL

**POLYMERIC CHAIN INSULATOR
FOR OVERHEAD LINES 138kV 160 kN**

DATA SHEET CODE ETED: DMI-GMR-059

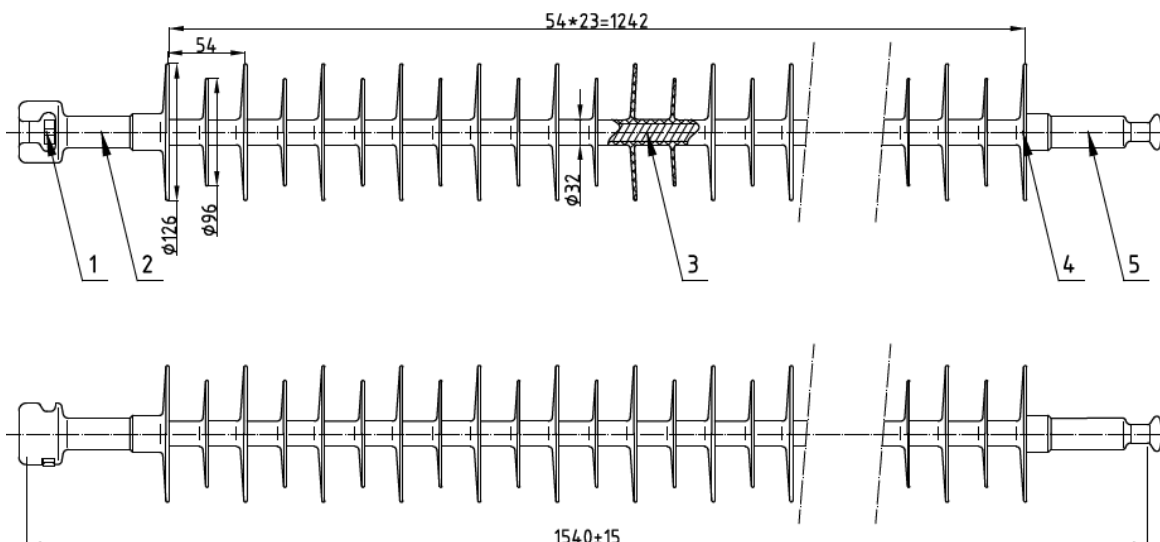

Main Characteristics:

- Continuous HTV Silicone Coating. .
- Hydrophobic Level Silicone HC2. Repels moisture accumulation.
- High Mechanical Efficiency Glass Fiber ERC Core 160 kN

Cod.	Service Voltage	Creepage Dist.	Min. Protected Line	Mechanical Load	Test Voltages	
C138160SB	<i>Ur</i>	<i>C.D.</i>	<i>Dry arc</i>	<i>SML</i>	1,2/50 BIL	50 Hz/WET
Drawing	kV	mm	mm	kN	kV	kV
GN0002622A	138	3625	1300	160	815	275

CHAIN INSULATORS



POLYMERIC CHAIN INSULATOR FOR OVERHEAD LINES OF 138 kV IEC 61109 STANDARD- END FITTINGS SOCKET-BALL

**POLYMERIC CHAIN INSULATOR
FOR OVERHEAD LINES 138kV 120 kN**

DATA SHEET CODE ETED: DMI-GMR-067

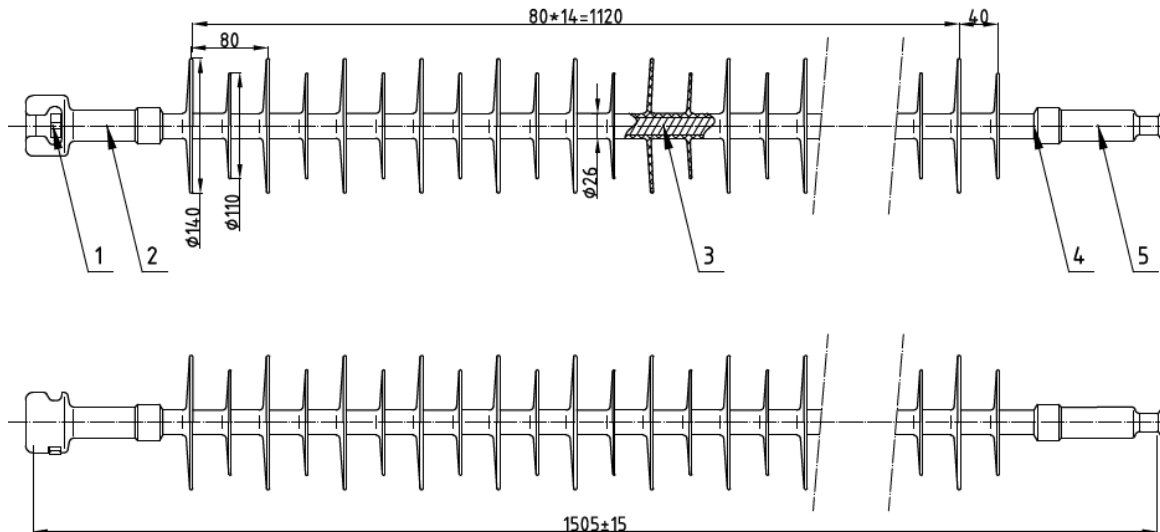

Main Characteristics:

- Continuous HTV Silicone Coating. .
- Hydrophobic Level Silicone HC2. Repels moisture accumulation.
- High Mechanical Efficiency Glass Fiber ERC Core 120 kN

Cod.	Service Voltage	Creepage Dist.	Min. Protected Line	Mechanical Load	Test Voltages	
					1,2/50 BIL	50 Hz/WET
C138120SB	<i>U_r</i>	<i>C.D.</i>	<i>Dry arc</i>	<i>SML</i>	kV	kV
GN0002621A	138	3625	1300	120	815	275

CHAIN INSULATORS





INSULATION SYSTEMS FOR M.V. / H.V. NETWORKS 15kV – 138kV



Model Index. New Aerial Lines and Network Adaptations

RIGID INSULATORS CAON®-KORWI®
PIN / LINE POST COMPOSITE INSULATORS
USE IN 15-138 KV DISTRIBUTION LINES

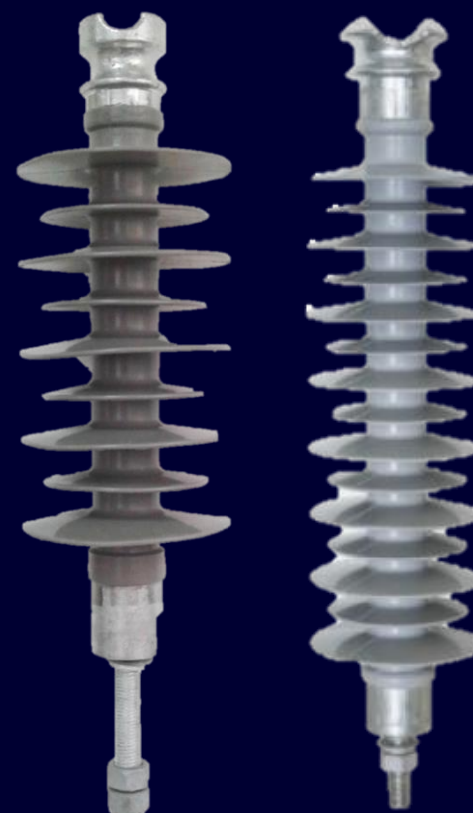

Pin Line Post Composite Insulators _ 15kV up to 138kV



RIGID INSULATOR 15kV 12,5kN – **DISNORTE-DISSUR.**

TECHNICAL DATA SHEET OF THE INSULATOR

Mod. : AIP015125_355

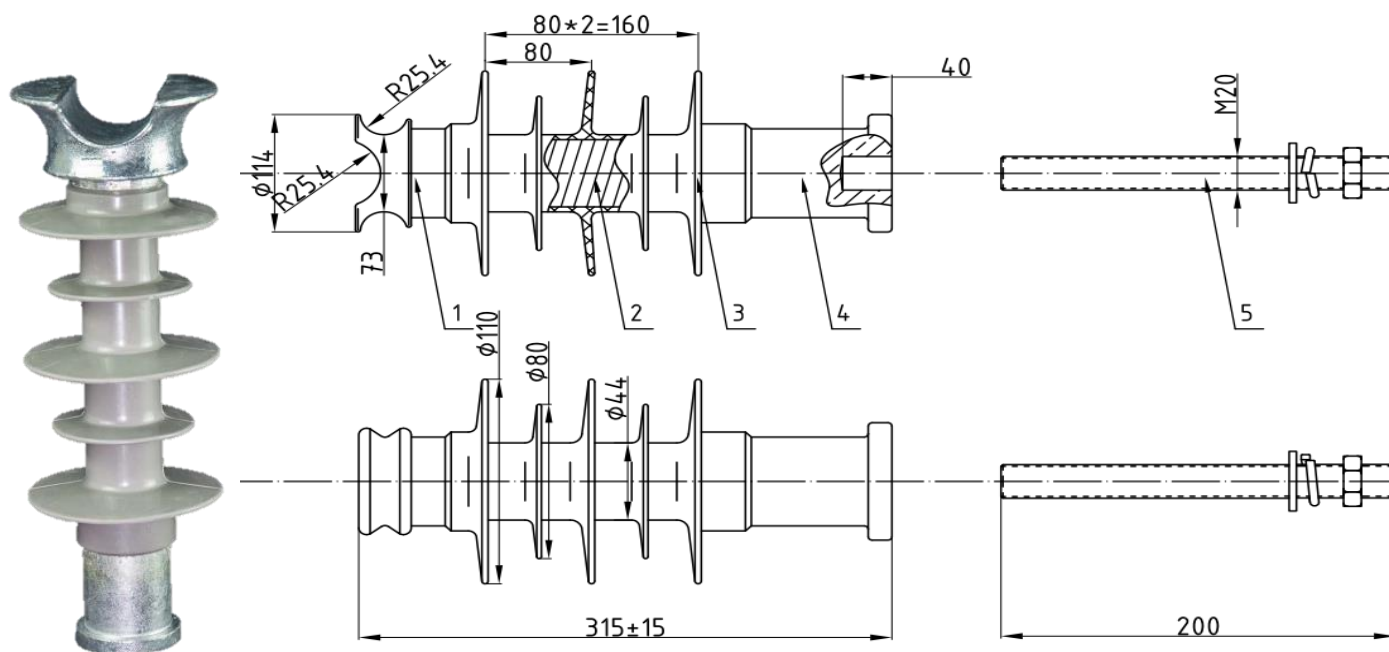

Main Characteristics:

- Suitable for High Pollution Areas. . Warranty : 10 Years.
- Continuous HTV Silicone Coating. .
- Production center certified ISO9001 – ISO14001.
- Hydrophobic Level Silicone HC2. Repels moisture accumulation.
- Glass Fiber Reinforced Resin Core (ECR) _ MDCL Routine 500daN.
- Hot-Dip Galvanized Fittings. HDG.
- Indelible Individual Marking: Brand-Model_Umax.(kV)_SCL(daN)_Date_Lot

Cod.	Service Voltage	Creepage Dist.	Min. Protected Line	Mechanical Load	Test Voltages			
					POS.BIL	NEG.BIL	F.I./WET	F.I./DRY
AIP015125_355	kV	mm	mm	daN	kV	kV	kV	kV
Weight(kg)	15	>355	>215	1245	130	155	60	80

PIN TYPE INSULATORS_ VASTAGO M-20



RIGID INSULATOR 25kV 12,5kN – DISNORTE-DISSUR.

TECHNICAL DATA SHEET OF THE INSULATOR

Mod. : AIP025125_622

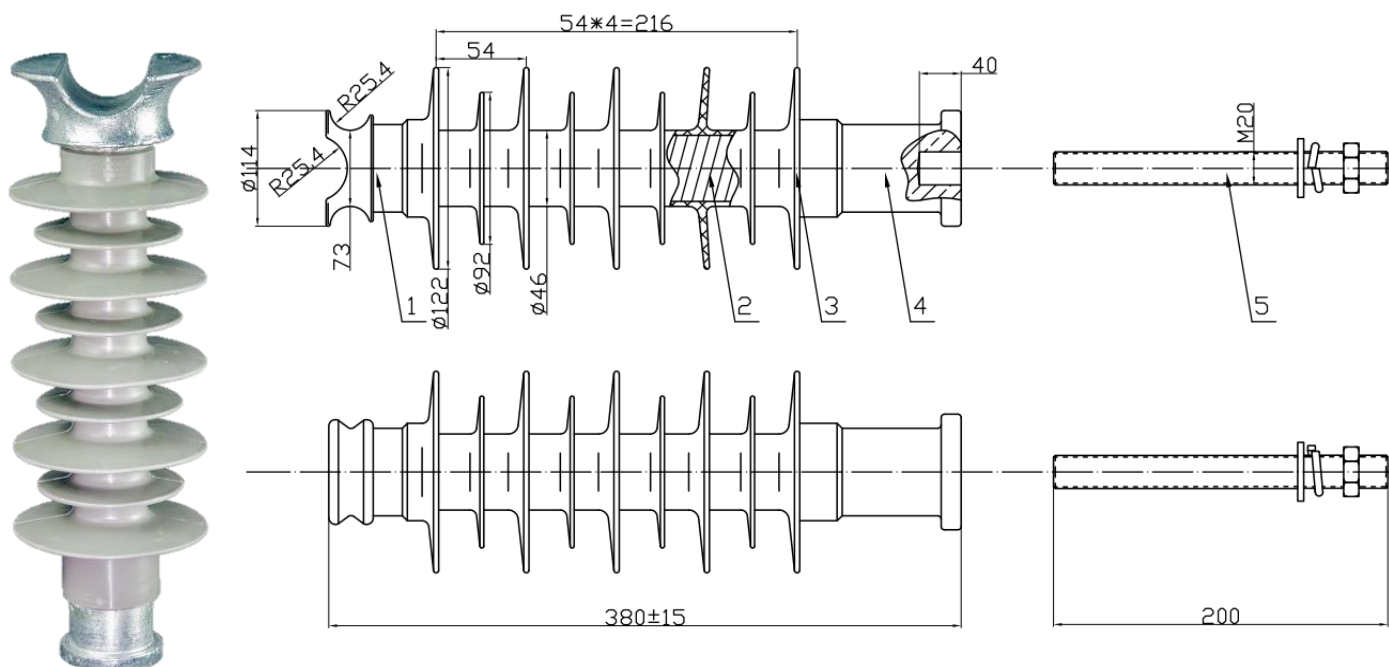

Main Characteristics:

- Suitable for High Pollution Areas. .
- Warranty : 10 Years.
- Continuous HTV Silicone Coating. .
- Production center certified ISO9001 – ISO14001.
- Hydrophobic Level Silicone HC2. Repels moisture accumulation.
- Glass Fiber Reinforced Resin Core(ECR) _ MDCL Routine 500daN.
- Hot-Dip Galvanized Fittings. HDG.
- Indelible Individual Marking: Brand-Model_Umax.(kV)_SCL(daN)_Date_Lot

Cod.	Service Voltage	Creepage Dist.	Min. Protected Line	Mechanical Load	Test Voltages			
					POS.BIL	NEG.BIL	F.I./WET	F.I./DRY
AIP025125_622	kV	mm	mm	daN	kV	kV	kV	kV
Weight(kg)	25	>622	>265	1245	180	205	85	110

PIN TYPE INSULATORS_ VASTAGO M-20



TECHNICAL DATA SHEET OF THE INSULATOR
REF.: FP-36/6-ARSI-30E

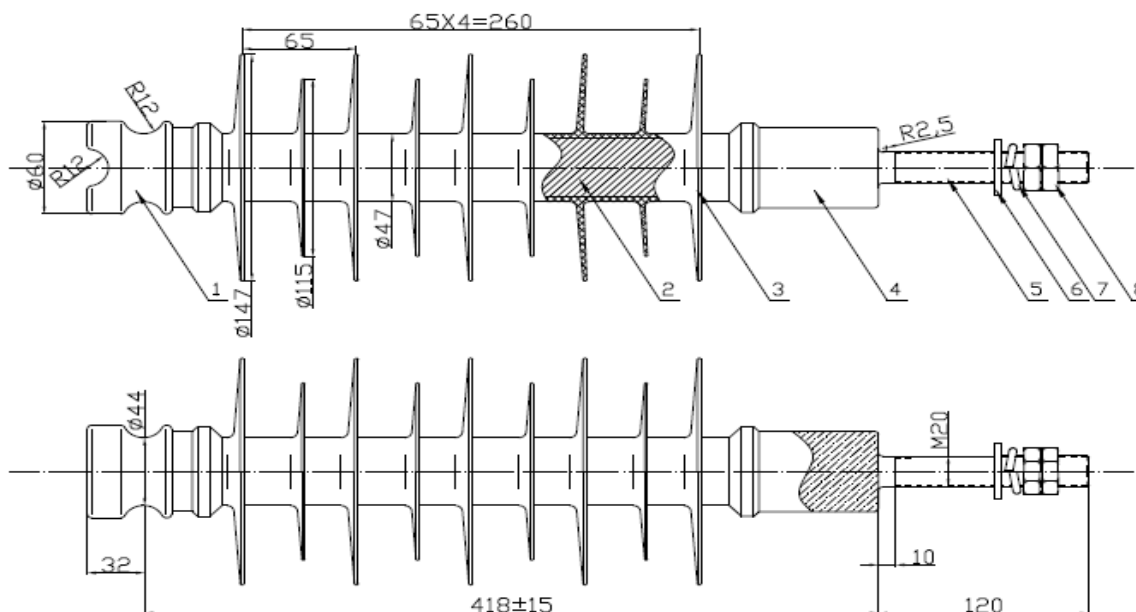
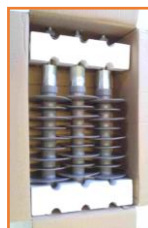

Main Characteristics:

- Designed for the Replacement of the ARVI Glass Insulator
- Equipped with Level III Leakage Path – IEC 60815
- Effective Performance in High Pollution Areas
- Equipped with Forged Steel Fittings and Fixed Zinc Steel Stem Zn.
- HC-2 Level Hydrophobic Silicone Coating
- High Mechanical Efficiency Glass Fiber ERC Core. 6kN.
- The design of the Upper Bracket allows the fixation of conductors in Vertical-Horizontal-Inclined positions using preformed rods or retainers.
- IEC Standard 60587 / CEI 61952 / AND012 – AND014 ENDESA _ GSCC010 Rev.02.

Cod.	Service Voltage	Creepage Dist.	Min. Protected Line	Mechanical Load	Test Voltages	
ARSI-30E	U_r	$C.D.$	$Dry\ arc$	SML	1,2/50 BIL	50 Hz/WET
Weight (kg)	kV	mm	mm	kN	kV	kV
3,925	36	100	370	6	200	90

PIN TYPE INSULATORS_ VASTAGO M-20 FIJO.



POLYMERIC POST LINE INSULATOR 36kV 12,5kN.

TECHNICAL SHEET AND MAIN FEATURES REF.: ARSI36125_FP-36/12,5

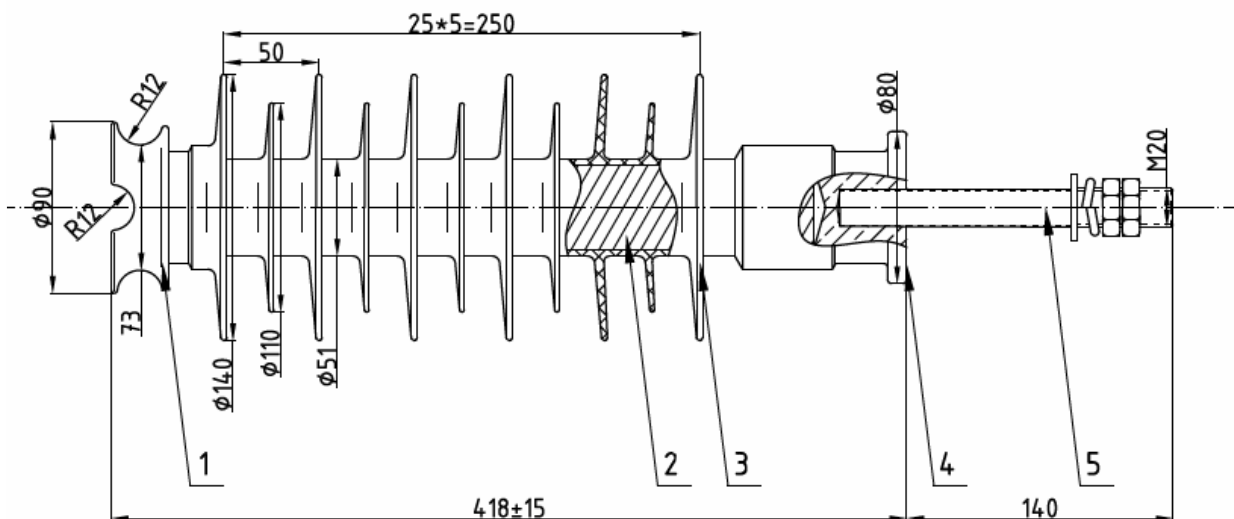

Main Characteristics:

- Creepage Distance Class III Level IEC 60815
- Better behaviour on high polluted areas.
- Hot Dip Galvanized Steel. Continuous and removable thread PIN length 140mm. Included 2pcs nut and spring+flash washer to assure the fixation for years.
- Silicone housing hydrophobic type Hc-2.
- Epoxy Resin Core 12,5kN,
- Double fixation way on up end fitting through side tie.
- Standard IEC 60587 / IEC 61952

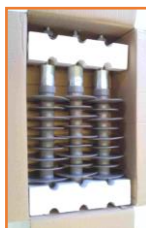

Cod.	Service Voltage	Creepage Dist.	Min. Protected Line	Mechanical Load	Test Voltages		HEIGHT
ARSI-30E	<i>U_r</i>	<i>C.D.</i>	<i>Dry arc</i>	<i>SML</i>	1,2/50 BIL	50 Hz/WET	L
Weight (kg)	kV	mm	mm	kN	kV	kV	mm
3,925	36	100	370	6	200	90	418

LINE POST INSULATOR_REMOVABLE PIN M-20



POLYMER HORIZONTAL POSITION POST-TYPE INSULATOR FOR 138 KV OVERHEAD LINES 11 KN KN_IEC 61952 STANDARD

**POLYMER POST-TYPE INSULATOR
FOR 138 KV OVERHEAD LINES 11 KN**

DATA SHEET CODE ETED: DMI-GMR-066

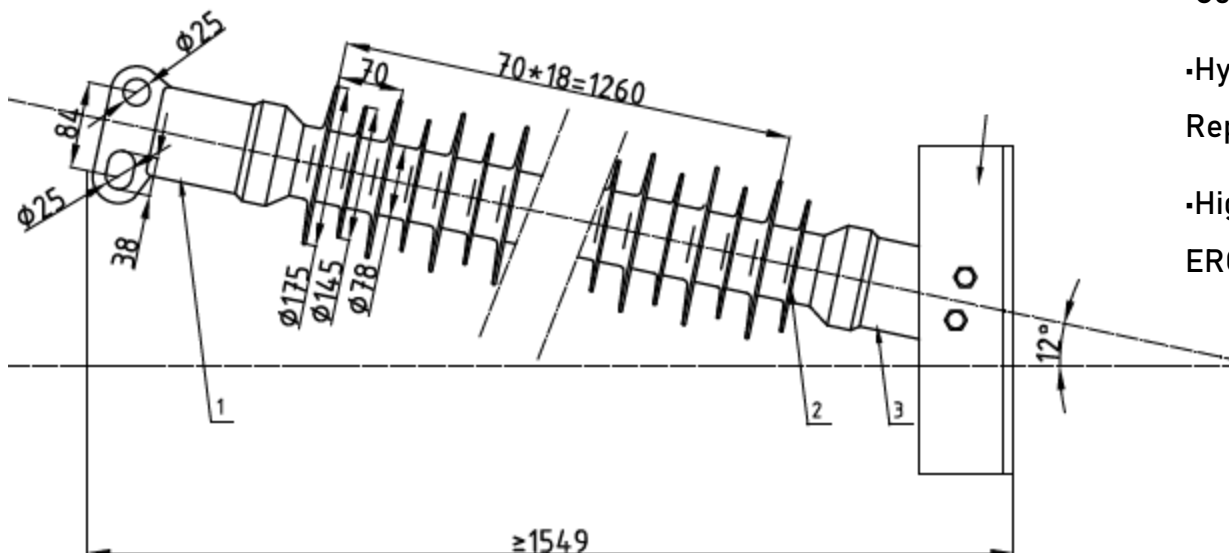

Main Characteristics:

- Continuous HTV Silicone Coating. .
- Hydrophobic Level Silicone HC2. Repels moisture accumulation.
- High Mechanical Efficiency Glass Fiber ERC Core 11 kN

Cod.	Service Voltage	Creepage Dist.	Min. Protected Line	Mechanical Load	Test Voltages	
FPS-138/11	<i>U_r</i>	<i>C.D.</i>	<i>Dry arc</i>	<i>SML</i>	1,2/50 BIL	60 Hz/WET
Drawing	kV	mm	mm	kN	kV	kV
GN0002620A	138	4060	1375	11	900	430

POST TYPE INSULATORS



POLYMER HORIZONTAL POSITION POST-TYPE INSULATOR FOR 69 KV OVERHEAD LINES 22 KN_IEC 61952 STANDARD

**POLYMER POST-TYPE INSULATOR
FOR 69 KV OVERHEAD LINES 22 KN**

DATA SHEET CODE ETED: DMI-GMR-065

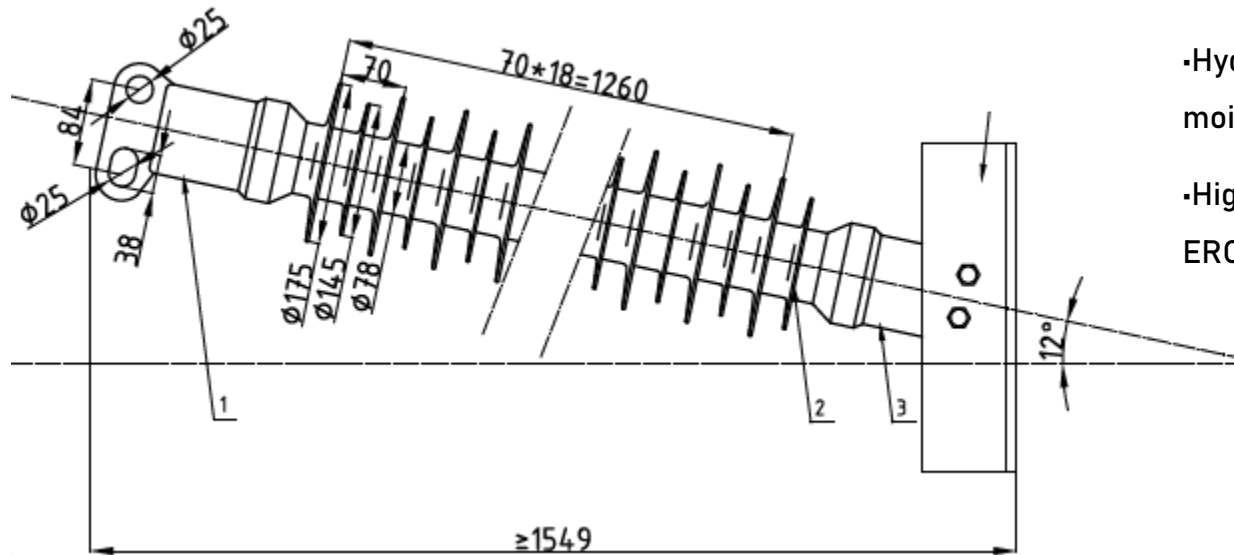

Main Characteristics:

- Continuous HTV Silicone Coating. .
- Hydrophobic Level Silicone HC2. Repels moisture accumulation.
- High Mechanical Efficiency Glass Fiber ERC Core 22 kN

Cod.	Service Voltage	Creepage Dist.	Min. Protected Line	Mechanical Load	Test Voltages	
FPS-69/22	<i>U_r</i>	<i>C.D.</i>	<i>Dry arc</i>	<i>SML</i>	1,2/50 BIL	60 Hz/WET
Drawing	kV	mm	mm	kN	kV	kV
GN0002625A	69	2030	717	22	475	230

POST TYPE INSULATORS



POLYMER HORIZONTAL POSITION PIN-TYPE INSULATOR FOR 69 KV OVERHEAD LINES 22 KN_IEC 61952 STANDARD

**POLYMER POST-TYPE INSULATOR
FOR 69 KV OVERHEAD LINES 22 KN**

DATA SHEET CODE ETED: DMI-GMR-068



Illustrative image of a similar insulator
Not representative.

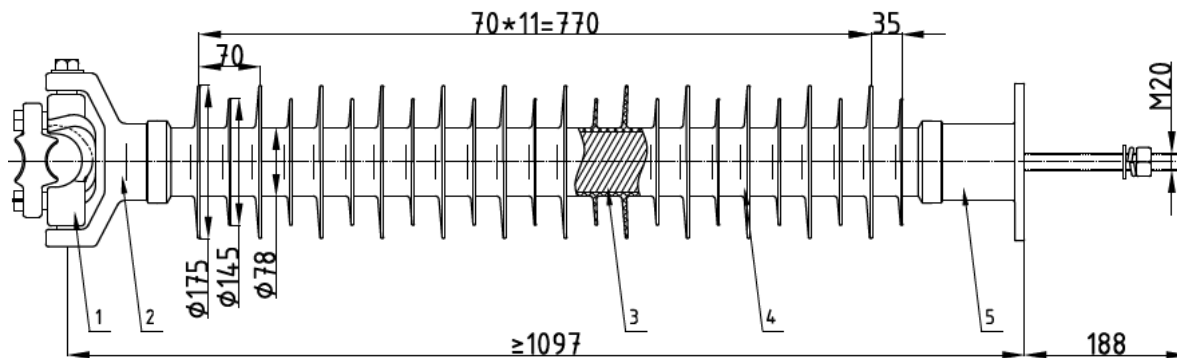

Main Characteristics:

- Continuous HTV Silicone Coating. .
- Hydrophobic Level Silicone HC2. Repels moisture accumulation.
- High Mechanical Efficiency Glass Fiber ERC Core 20 kN

PIN TYPE INSULATORS

Cod.	Service Voltage	Creepage Dist.	Min. Protected Line	Mechanical Load	Test Voltages	
FPS-69/20	<i>Ur</i>	<i>C.D.</i>	<i>Dry arc</i>	<i>SML</i>	1,2/50 BIL	60 Hz/WET
Drawing	kV	mm	mm	kN	kV	kV
GN0002626A	69	2362	864	20	530	230





INSULATION SYSTEMS IN NETWORKS MV / HV 15kV – 245kV



MODEL INDEX

SUPPORT INSULATORS CAON®-KORWI®
POST / SUBSTATION COMPOSITE INSULATORS
USE IN NETWORKS 15-245kV.



Composite Insulators - 15kV up to 245kV



SUPPORT INSULATOR 15 kV 5kN _ POLLUTION LEVEL c .

TECHNICAL DATA SHEET OF THE INSULATOR

AIP0125IIP _ 15kV 5kN – M10/M12

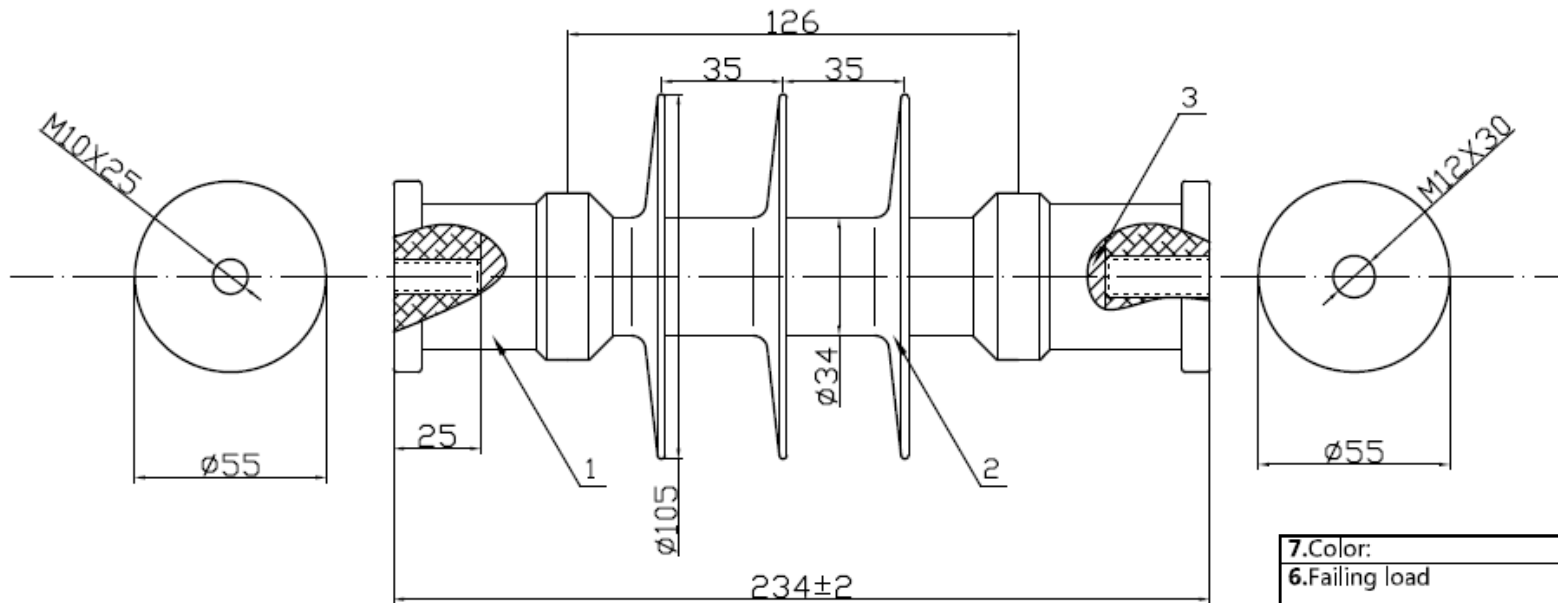

3	Core	1	Fiberglass rod	∅28
2	Weathersheds	3	Silicon rubber	
1	End fitting	2	Galvanized steel	
ITEM	DESCRIPTION	Q'TY	MATERIAL	REMARK

7.Color:	Red/Grey
6.Failing load	Bent:5kN Distortion:0.6kN/m
5.Critical impulse volatge:	Pos:75kV Neg:75kV
4.1min power frequency withstand vptage:	Dry:55kV Wet:45kV
3.Arcing distance:	140mm
2.Creepage distance:	350mm
1.Standard IEC:	61952

TECHNICAL DETAILS.

TITLE
12 KV COMPOSITE POST INSULATOR

MV SUPPORT INSULATORS.



SUPPORT INSULATOR AIPO245IIIP/2 _C3CX016 - 24 kV 5kN _ POLLUTION LEVEL *d*.

**TECHNICAL DATA SHEET OF THE INSULATOR SUPPORT
INSULATOR CAON AIPO245IIIP/2 _C3CX016 - 24 kV**

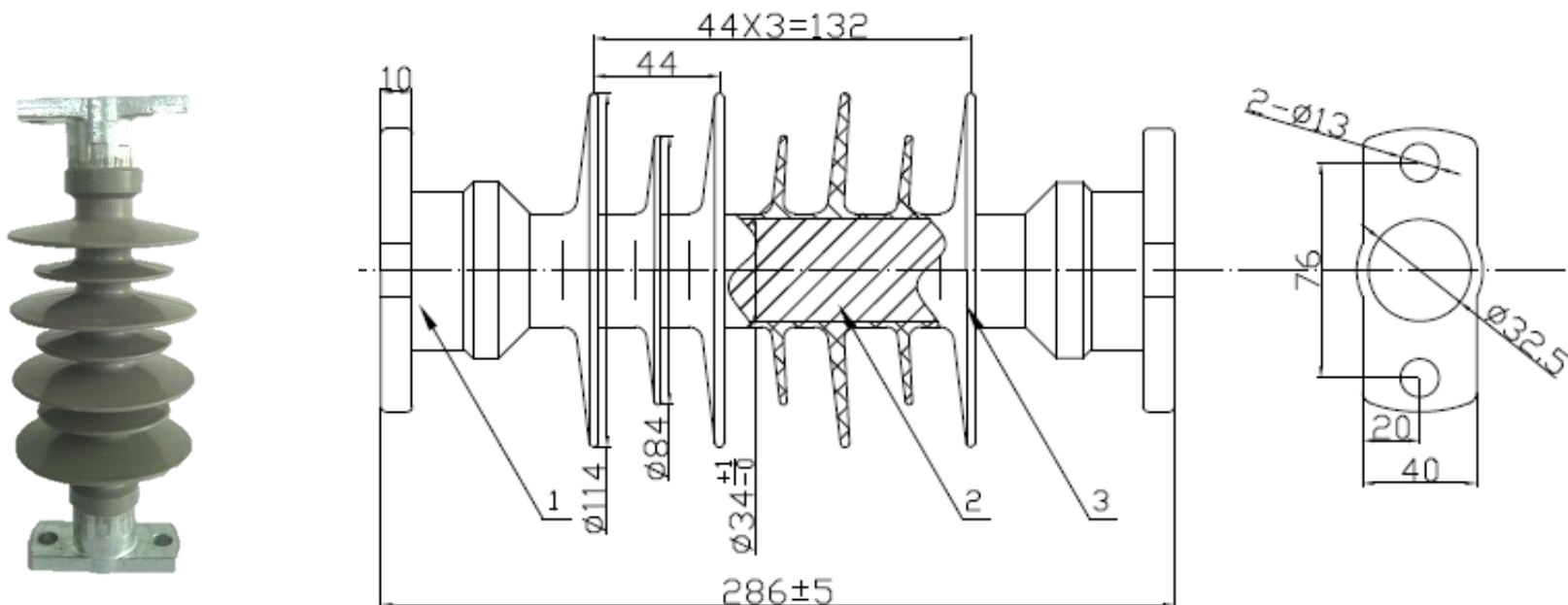

Cod. Mod.	Service Voltage	Creepage Dist.	Min. Protected Line	Mechanical Load	Test Voltages		
	kV				mm	SCL-kN	SML-kN
						kV	kV
AIPO245IIIP/2	24	610	5	25	150	68	

MV SUPPORT INSULATORS



SUPPORT INSULATOR AIPO363IIP/2 _C3CX017 - 36 kV 4kN _ POLLUTION LEVEL *d*.

TECHNICAL DATA SHEET OF THE INSULATOR
APOYO CAON AIPO363IIP/2 _C3CX017 - 36 kV 4 kN

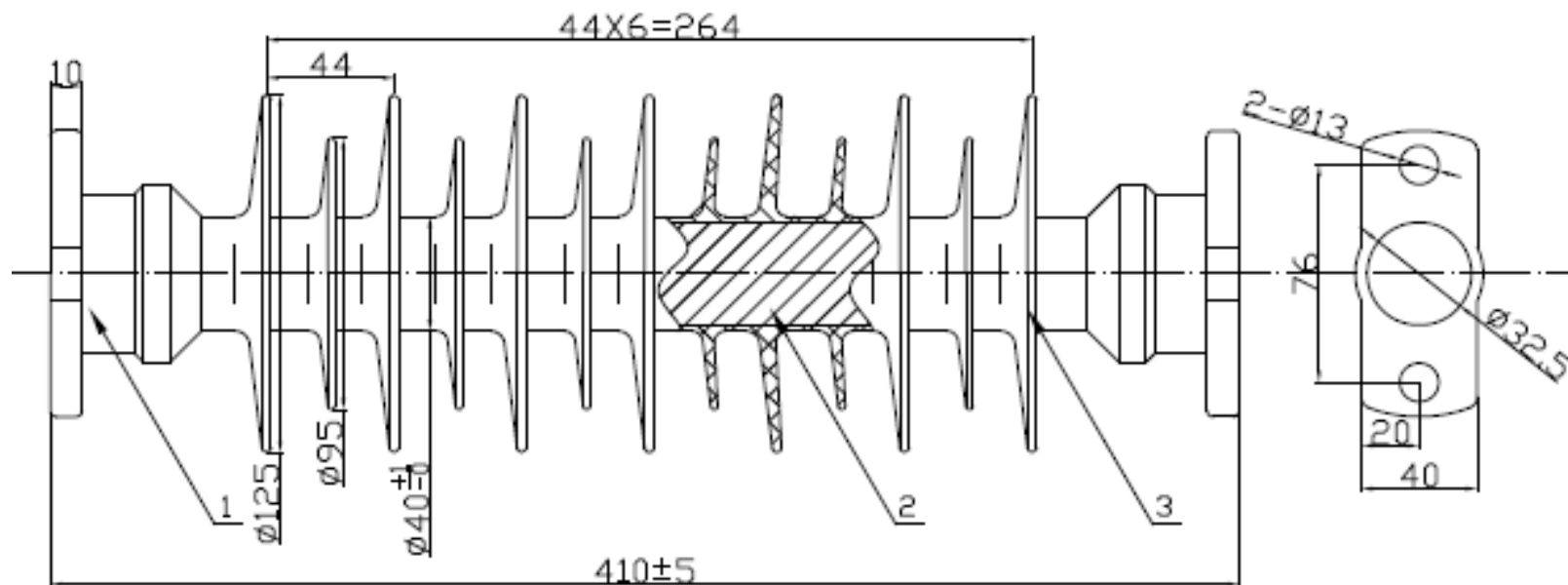

Cod. Mod.	Service Voltage	Creepage Dist.	Min. Protected Line	Mechanical Load	Test Voltages	
	kV				mm	SCL-kN
AIPO364IIP/2	36	1104	4	25	200	80

MV SUPPORT INSULATORS



SUPPORT INSULATOR AIPO2410IIP 24 kV 10kN _ POLLUTION LEVEL *d*.

TECHNICAL DATA SHEET
REF. : AIPO2410IIP

- SILICONE COATING HYDROFOBICITY LEVEL Hc2.
- ERC FORTIFICIED ACID-PROOF CORE
- DEVELOPED TO USE IN RURAL POWER GRID > 14.500pcs.



Illustrative image of a similar insulator
Not representative.

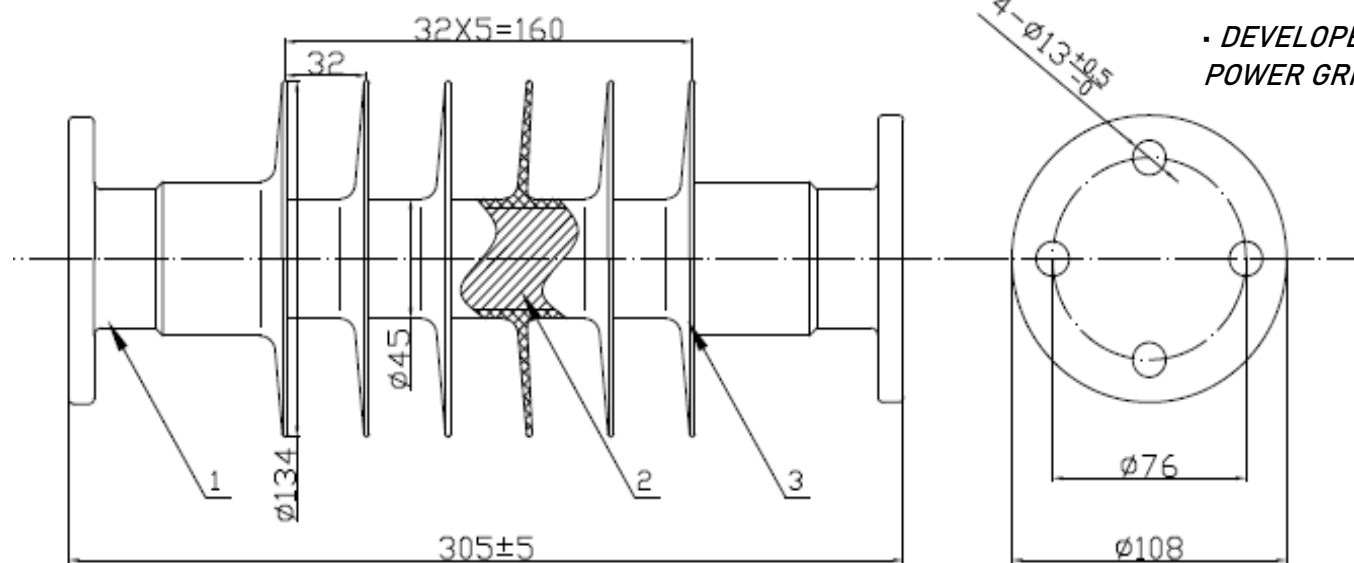

- HTV SILICONE POLYMER COATING_HYDROPHOBICITY HC2.
- SPECIFIC DESIGN. HYDROLYSIS-RESISTANT CORE.
- PRODUCT DEVELOPED FOR USE IN RURAL ELECTRIFICATION. > 14,500 UNITS MANUFACTURED.

Cod. Mod.	Service Voltage	Creepage Dist.	Min. Protected Line	Mechanical Load	Test Voltages		HEIGHT
	kV				mm	SCL-kN	
AIPO2410IIP	24	660	280	10	125	50	305

MV SUPPORT INSULATORS



SUPPORT INSULATOR AIPO2515IIP 25 kV 15kN _ POLLUTION LEVEL e .

TECHNICAL DATA SHEET
REF. : AIPO2515IIP

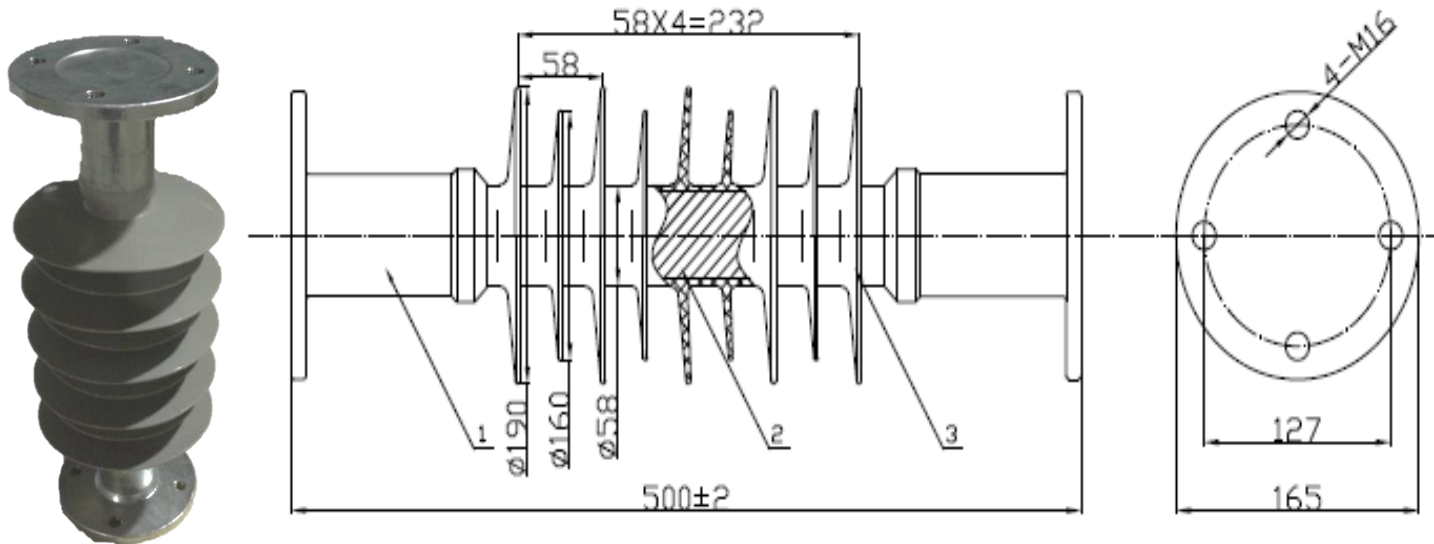

- HYDROPHOBIC POLYMER COATING TYPE Hc2.
- SPECIFIC DESIGN. HYDROLYSIS-RESISTANT CORE.
- PRODUCT DEVELOPED FOR USE IN RAILWAY CATENARY IN THE MIDDLE EAST. 3110 UNITS.

- SILICONE COATING HYDROFOBICITY LEVEL Hc2.
- ERC FORTIFICIED ACID-PROOF CORE .
- DEVELOPED TO USE IN RAILWAY CATENARY. MIDDLE EAST. 3 110pcs.

Cod. Mod.	Service Voltage	Creepage Dist.	Min. Protected Line	Mechanical Load	Test Voltages		HEIGHT
	kV				mm	SCL-kN	SML-kN
AIPO2515IIP	25	1200	365	15	170	70	500

MV SUPPORT INSULATORS.



SUPPORT INSULATOR AIPO365IIP 36 kV 5kN _ POLLUTION LEVEL *d*.

TECHNICAL DATA SHEET
REF. : AIPO365IIP

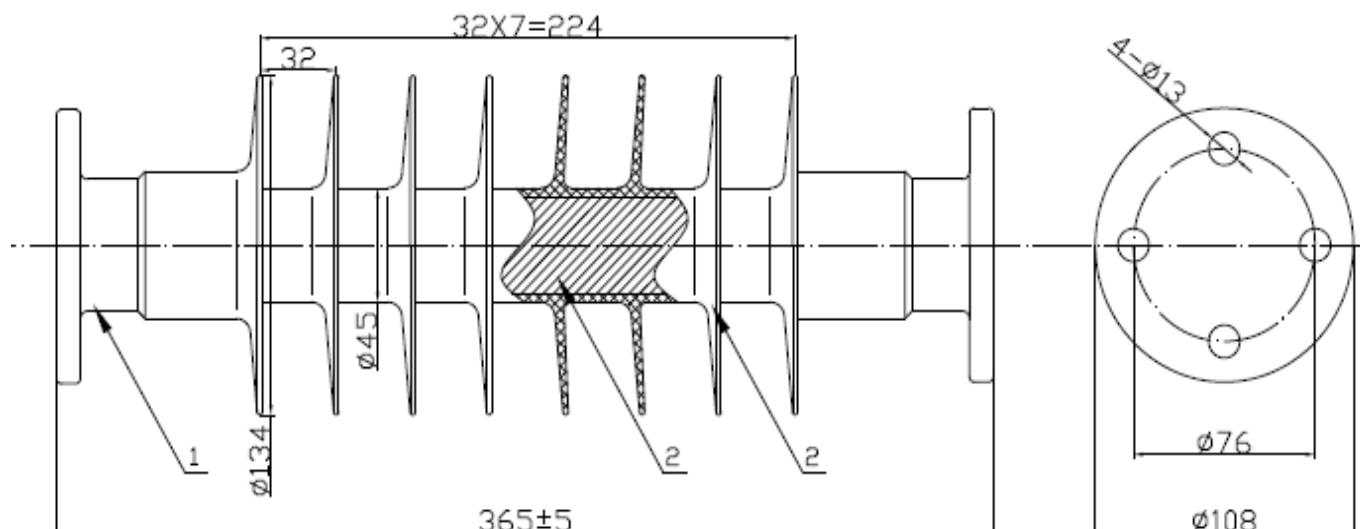

- SILICONE COATING HYDROPHOBICITY LEVEL Hc2.
- ERC FORTIFICIED ACID-PROOF CORE .
- DEVELOPED TO USE IN RURAL POWER GRID > 14.500Pcs.

Illustrative image of a similar insulator
Not representative.

- HTV SILICONE POLYMER COATING_HYDROPHOBICITY HC2.
- SPECIFIC DESIGN. HYDROLYSIS-RESISTANT CORE.
- PRODUCT DEVELOPED FOR USE IN RURAL ELECTRIFICATION. > 14,500 UNITS MANUFACTURED.

Cod. Mod.	Service Voltage	Creepage Dist.	Min. Protected Line	Mechanical Load	Test Voltages		HEIGHT
	kV				mm	SCL-kN	SML-kN
AIPO365IIP	36	933	340	5	170	70	365

MV SUPPORT INSULATORS



SUPPORT INSULATOR AIP0524P 52kV 4kN _ POLLUTION LEVEL *d*.

TECHNICAL DATA SHEET

REF. : AIP0524P

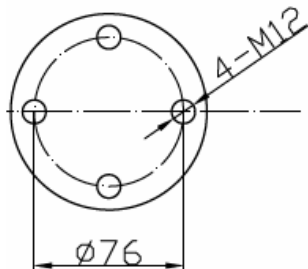
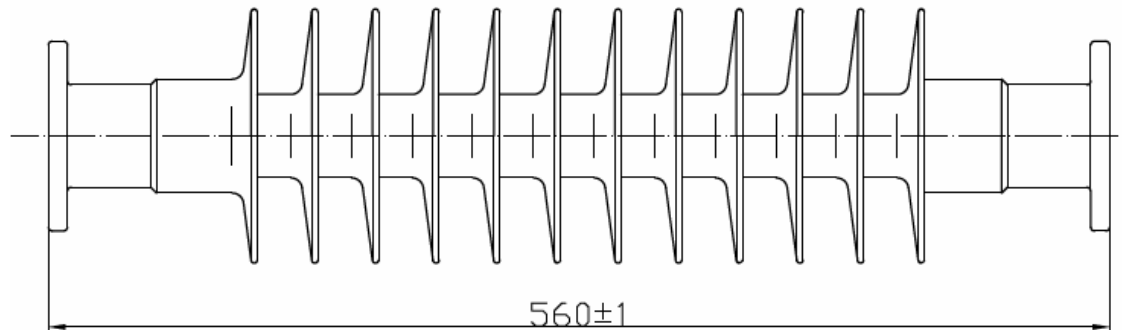

Illustrative image. It may not correspond to the model indicated in this sheet.

Main Characteristics:

- Insulator Weight : 5,10 Kg
- Suitable for High Pollution Areas .
- Warranty : 15 Years.
- Continuous HTV Silicone Coating. .
- Hydrophobic Level Hc2 Silicone. Repels the Accumulation of Condensation, Water, and Ice.
- High Mechanical Efficiency Glass Fiber ERC Core C.M.E. 4 kN
- Better performance in high pollution areas.

Cod. Mod.	Service Voltage	Creepage Dist. mm	Min. Protected Line SCL-kN	Mechanical Load SML-kN	Test Voltages		HEIGHT
	kV				1,2/50 BIL kV	50 Hz/WET kV	L mm
AIP0524P	45/52	1320	480	4	250	120	560



SUPPORT INSULATOR AIP0528P 52kV 8kN _ POLLUTION LEVEL e .

TECHNICAL DATA SHEET

REF. : AIP0528P

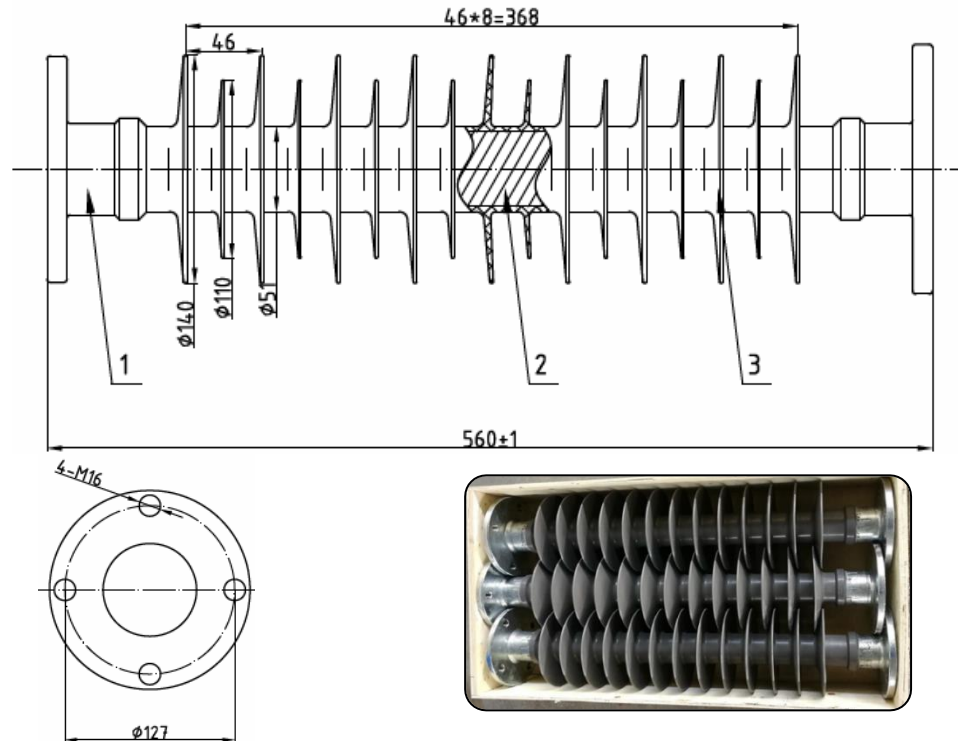

Illustrative image. It may not correspond to the model indicated in this sheet.

Main Characteristics:

- Insulator Weight : 6,40 Kg
- Suitable for High Pollution Areas .
- Warranty : 15 Years.
- Continuous HTV Silicone Coating .
- Hydrophobic Level Hc2 Silicone. Repels the Accumulation of Condensation, Water, and Ice.
- High Mechanical Efficiency Glass Fiber ERC Core C.M.E. 8 kN
- Better performance in high pollution areas.

Cod. Mod.	Service Voltage	Creepage Dist.	Min. Protected Line	Mechanical Load	Test Voltages		HEIGHT
					1,2/50 BIL	50 Hz/WET	L
AIP0524P	kV	mm	SCL-kN	SML-kN	kV	kV	mm
Drawing							
GN0002709A	45/52	1612	480	8	250	120	560



SUPPORT INSULATOR AIP0726P 72,5kV 5kN _ POLLUTION LEVEL *d*.

TECHNICAL DATA SHEET

REF. : AIP0726P

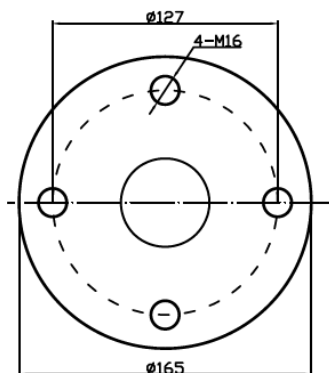
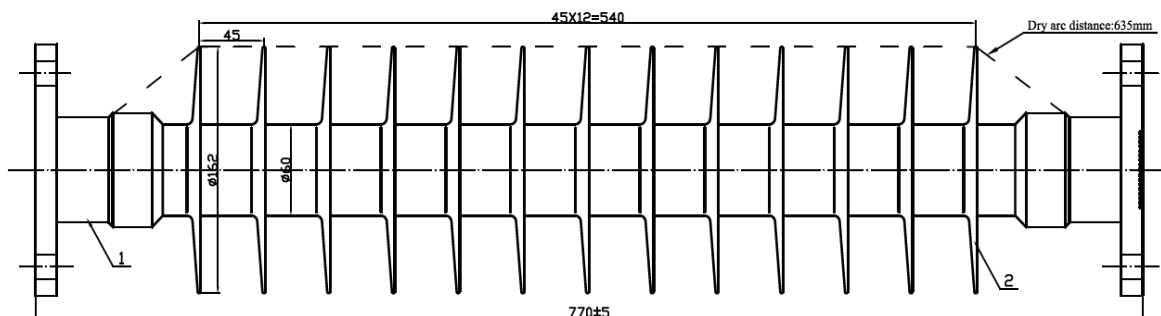

Main Characteristics:

- Insulator Weight : 11,50 Kg
- Suitable for Very High Contamination Areas. Warranty : 15 Years.
- Continuous HTV Silicone Coating. .
- Hydrophobic Level Silicone HC2. Repels moisture accumulation.
- High Mechanical Efficiency Glass Fiber ERC Core C.M.E. 6 kN
- Better performance in high pollution areas.
- -> 1,500 supplied in Spain.

Cod. Mod.	Service Voltage	Creepage Dist.	Min. Protected Line	Mechanical Load	Test Voltages		HEIGHT
	kV				mm	SCL-kN	SML-kN
AIP0726P	66/72,5	1830	635	6	325	140	770

HV SUPPORT INSULATORS_2ND CATEGORY LINES



SUPPORT INSULATOR AIP01326P 132kV 6kN _ POLLUTION LEVEL *d*.

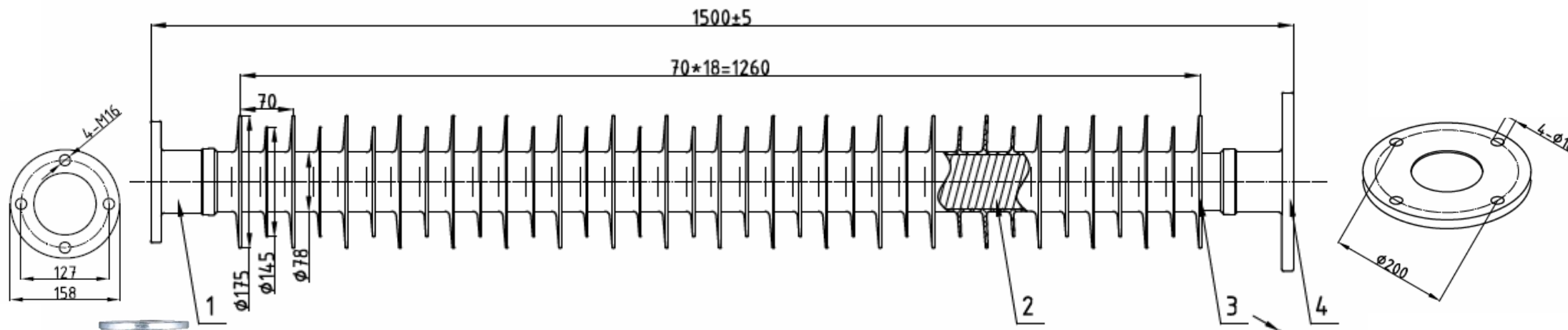

Illustrative image. It may not correspond to the model indicated in this sheet.

Main Characteristics:

- Suitable for High Pollution Areas . Nivel III 25mm/kV.
- Warranty : 15 Years.
- Continuous HTV Silicone Coating. .
- Hydrophobic Level Silicone HC2. Repels moisture accumulation.
- High Mechanical Efficiency Glass Fiber ERC Core C.M.E. 6 kN

Technical Specifications:

9. Power frequency flashover voltage	Dry :410kV Wet :340kV
8. Power frequency withstand voltage	Dry :375kV Wet :310kV
7. Torsional strength:	4.5kN
6. Compression strength:	160kN
5. Specified cantilever load(SCL):	6kN
4. Specified tension load(STL):	80kN

Cod. Mod.	Service Voltage	Creepage Dist.	Min. Protected Line	Mechanical Load	Test Voltages		HEIGHT
					1,2/50 BIL	50 Hz/WET	L
AIP01326IIP	Ur/Um kV	C.D. mm	SCL-kN	SML-kN	kV	kV	mm
GN0001989A	110/132	3700	1340	6	650	310	1500



SUPPORT INSULATOR AIP013210P 132kV 10kN _ POLLUTION LEVEL *d*.

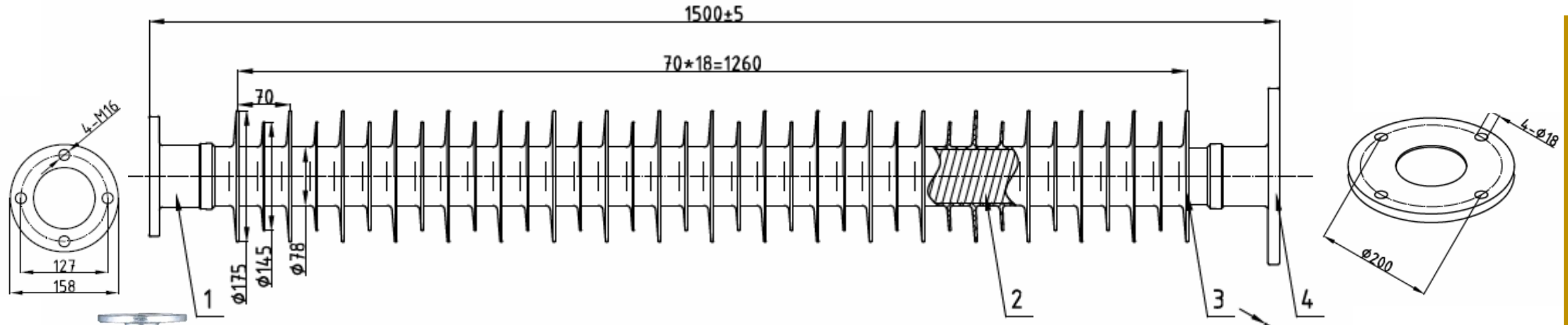

Illustrative image. It may not correspond to the model indicated in this sheet.

Main Characteristics:

- Suitable for High Pollution Areas . Nivel III 25mm/kV.
- Warranty : 15 Years.
- Continuous HTV Silicone Coating. .
- Hydrophobic Level Silicone HC2. Repels moisture accumulation.
- High Mechanical Efficiency Glass Fiber ERC Core C.M.E. 10 kN

Technical Specifications:

7.Torsional strength:	4.5kN
6.Compression strength:	160kN
5.Specified cantilever load(SCL):	10kN
4.Specified tension load(STL):	80kN
3.Dry arcing distance:	1340mm

Cod. Mod.	Service Voltage	Creepage Dist.	Min. Protected Line	Mechanical Load	Test Voltages		HEIGHT
					1,2/50 BIL	50 Hz/WET	L
AIP013210P	Ur/Um kV	C.D. mm	SCL-kN	SML-kN	kV	kV	mm
GN0001989B	132/145	3700	1340	10	650	310	1500

INSULATORS SUPPORT HV_1ST CATEGORY LINES



SUPPORT INSULATOR AIP01456P 145kV 6kN _ POLLUTION LEVEL e.

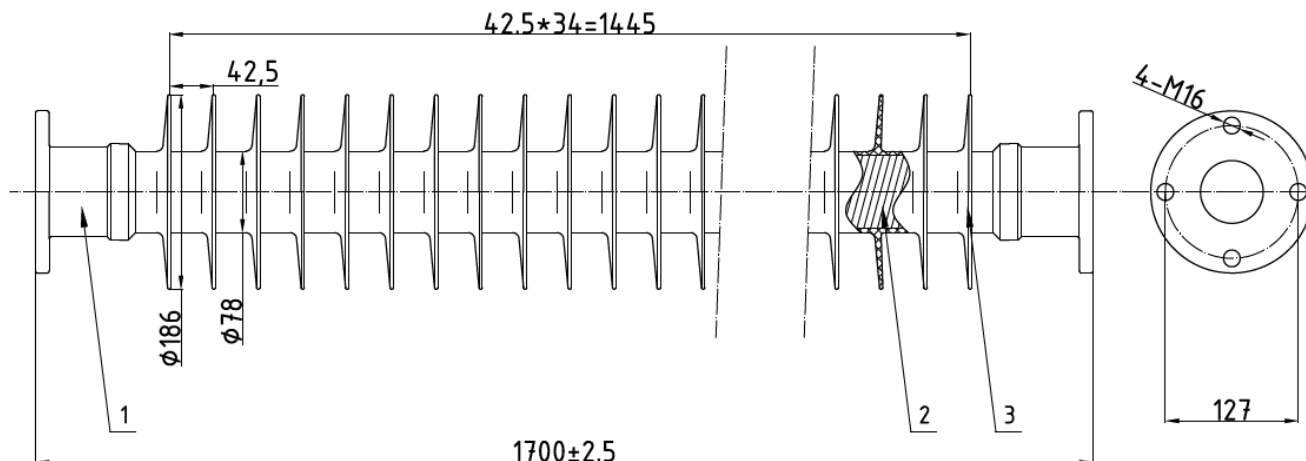

Main Characteristics:

- Suitable for Very High Contamination Areas.
- Warranty : 15 Years.
- Continuous HTV Silicone Coating.
- Hydrophobic Level Silicone HC2. Repels moisture accumulation.
- High Mechanical Efficiency Glass Fiber ERC Core C.M.E. 6 kN
- Better performance in high pollution areas.



ILLUSTRATIVE AND NOT REPRESENTATIVE IMAGE

Cod. Mod.	Service Voltage	Creepage Dist.	Min. Protected Line	Mechanical Load	Test Voltages		HEIGHT
					1,2/50 BIL	50 Hz/WET	L
AIP0145/4700	Ur/U _m	C.D.	SCL-kN	SML-kN	kV	kV	mm
Drawing	kV	mm					
GN0002149A	145	4700	1580	6	750	325	1700

INSULATORS SUPPORT HV_1ST CATEGORY LINES



SUPPORT INSULATOR AIPO2208P 220kV 8kN _ POLLUTION LEVEL e.

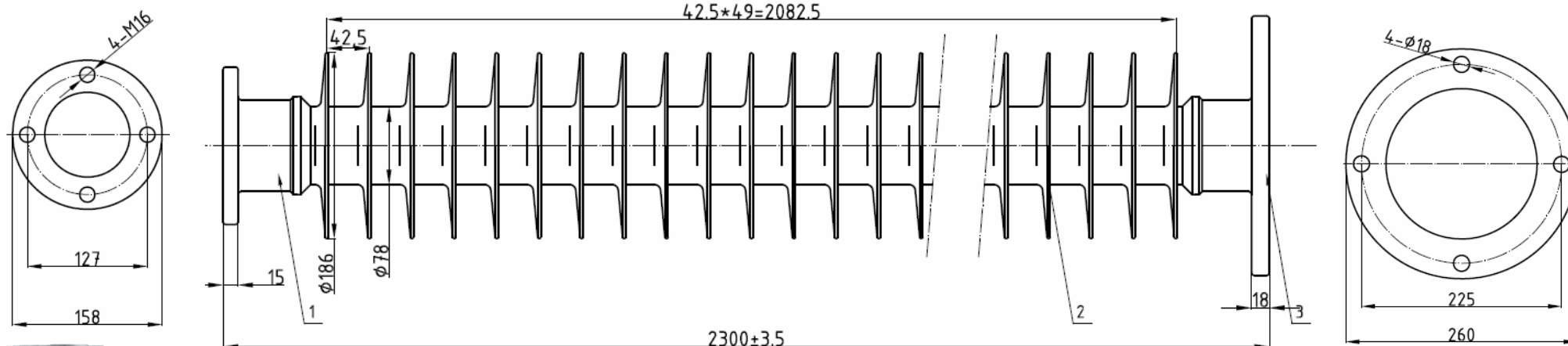

Illustrative image. It may not correspond to the model indicated in this sheet.

Main Characteristics:

- Suitable for Very High Contamination Areas. Nivel IV 31,5mm/kV.
- Warranty : 15 Years.
- Continuous HTV Silicone Coating. .
- Hydrophobic Level Silicone HC2. Repels moisture accumulation.
- High Mechanical Efficiency Glass Fiber ERC Core C.M.E. 8 kN

Technical Specifications:

10.Colour :	Light Gray
9.Standard:	IEC61952-2008
8.Dry arcing distance:	2200mm
7.Creepage distance:	6930mm
6.Compression:	650N*m
5.specified tensile load(STL):	25kN
4.Maximum design cantilever load(MDCL):	3kN
3.Specified cantilever load(SCL):	8kN
2.Lightning impulse withstand voltage:	Pos:1050kV
1.Power frequency withstand voltage:	Dry:550kV Wet:460kV

Cod. Mod.	Service Voltage	Creepage Dist. mm	Min. Protected Line SCL-kN	Mechanical Load SML-kN	Test Voltages		HEIGHT
	Ur kV				1,2/50 BIL kV	50 Hz/WET kV	L mm
AIPO2208IV	220	6930	2200	8	1050	460	2300

INSULATORS SUPPORT HV_1ST CATEGORY LINES



SUPPORT INSULATOR AIP02458P 245kV 8kN _ POLLUTION LEVEL e .

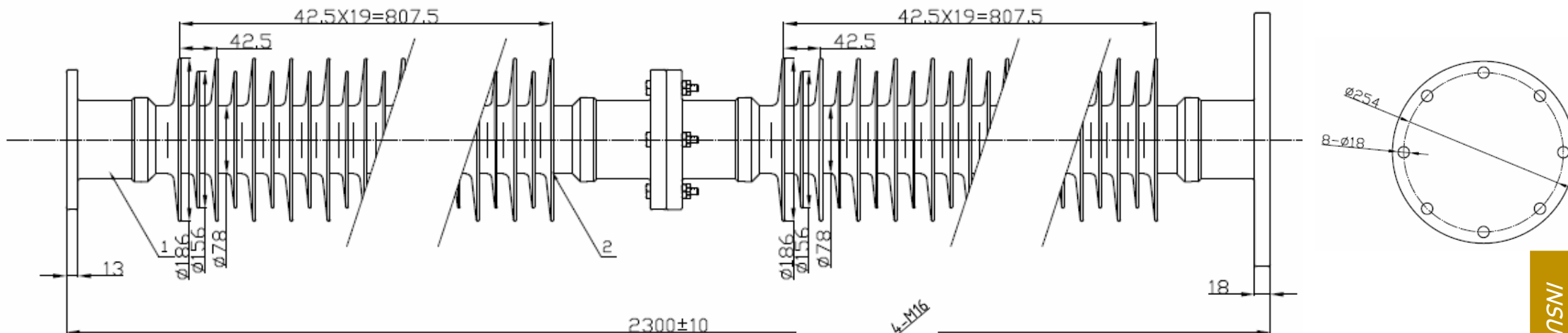

Illustrative image. It may not correspond to the model indicated in this sheet.

Main Characteristics:

- Suitable for Very High Contamination Areas. Nivel IV 31,5mm/kV.
- Warranty : 15 Years.
- Continuous HTV Silicone Coating. .
- Hydrophobic Level Silicone HC2. Repels moisture accumulation.
- High Mechanical Efficiency Glass Fiber ERC Core C.M.E. 8 kN

Technical Specifications:

7.Manufacturing method:	One completely molded
6.Standard:	IEC61952
5.Critical impulse withstand	Positive :1050kV
4.Minimum creepage distance:	7595mm
3.Power frequency withstand	Wet :390kV
2.Minimum bending strength:	8kN
1.Umax voltage	245kV

Cod. Mod.	Service Voltage	Creepage Dist.	Min. Protected Line	Mechanical Load	Test Voltages		HEIGHT
					1,2/50 BIL	50 Hz/WET	L
AIP02458P	Ur/Um kV	C.D. mm	SCL-kN	SML-kN	kV	kV	mm
GN0001153D	220/245	7595	1500	8	1050	390/460	2300

INSULATORS SUPPORT HV_1ST CATEGORY LINES



SUPPORT INSULATOR AIPO24510P 245kV 10kN _ POLLUTION LEVEL e.

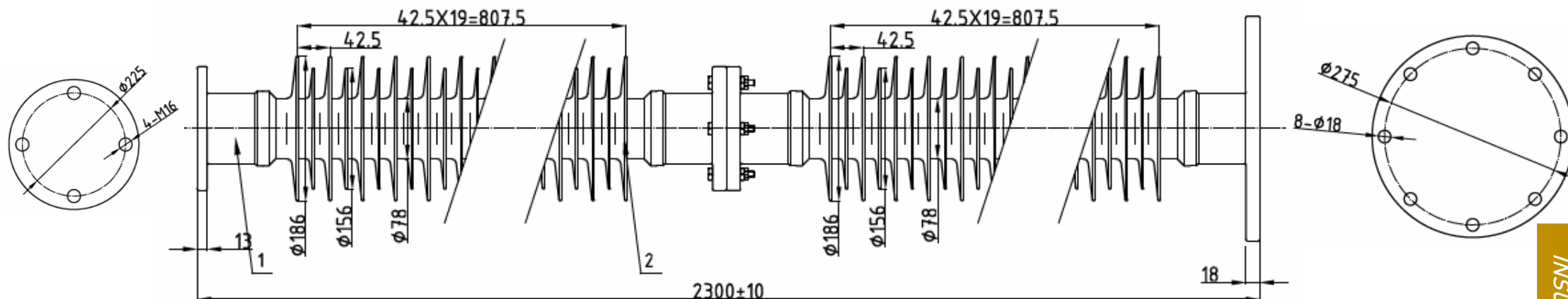

Illustrative image. It may not correspond to the model indicated in this sheet.

Main Characteristics:

- Suitable for Very High Contamination Areas. Nivel IV 31,5mm/kV.
- Warranty : 15 Years.
- Continuous HTV Silicone Coating. .
- Hydrophobic Level Silicone HC2. Repels moisture accumulation.
- High Mechanical Efficiency Glass Fiber ERC Core C.M.E. 10 kN

Technical Specifications:

7.Colour :	Grey
6.Standard:	IEC-61952
5.Creepage distance :	7595mm
4.Maximum design cantilever load(MDCL)	5kN
3.Specified cantilever load (SCL):	10kN
2.Lightning impulse withstand	Pos:1050kV
1.Power frequency withstand	Dry :460kV Wet :390kV

Cod. Mod.	Service Voltage	Creepage Dist.	Min. Protected Line	Mechanical Load	Test Voltages		HEIGHT
					1,2/50 BIL	50 Hz/WET	L
AIPO24510P	Ur/Um kV	C.D. mm	SCL-kN	SML-kN	kV	kV	mm
GN0002710A	220/245	7595	1500	10	1050	390/460	2300

INSULATORS SUPPORT HV_1ST CATEGORY LINES

COD199P50



SUPPORT INSULATOR AIPO4005P 400kV 5kN _ POLLUTION LEVEL e .

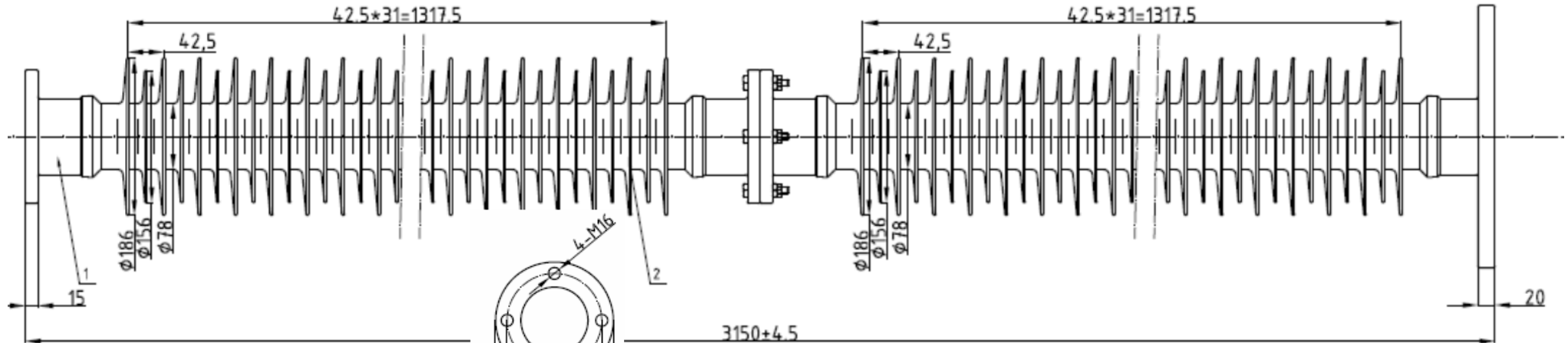

Illustrative image. It may not correspond to the model indicated in this sheet.

Main Characteristics:

- Suitable for Very High Contamination Areas. Nivel IV 31,5mm/kV.
- Warranty : 15 Years.
- Continuous HTV Silicone Coating. .
- Hydrophobic Level Silicone HC2. Repels moisture accumulation.
- High Mechanical Efficiency Glass Fiber ERC Core C.M.E. 5 kN

Technical Specifications:

10.Colour :	Light Gray
9.Standard:	IEC61952-2008
8.Dry arcing distance:	1500mm
7.Creepage distance:	12600mm
6.Compression:	650N*m
5.specified tensile load(STL):	25kN
4.Maximum design cantilever load(MDCL):	3kN
3.Specified cantilever load(SCL):	5kN
2.Lightning impulse withstand voltage:	Pos:1450kV
1.Power frequency withstand voltage:	Dry:1150kV Wet:950kV

Cod. Mod.	Service Voltage Ur kV	Creepage Dist. mm	Min. Protected Line SCL-kN	Mechanical Load SML-kN	Test Voltages		HEIGHT L mm
					1,2/50 BIL kV	50 Hz/WET kV	
AIPO40005IV	400	12600	1500	5	1450	950	3150





AVIFAUNA ISOLATION AND PROTECTION SYSTEMS IN MV / HV NETWORKS 15 KV – 72.5 KV



Model Index

Avifauna Insulators for ZEPA

Bird Protection Insulators for use in High Environmental Value Areas

CAON®-KORWI®



EDISTRIBUCIÓN - ENEL TAM 300020 / GSCC010 _ 2ªEd.



Totally Isolated Surface $\geq 1m$



I-DE Smart Electrical Networks 4803214 / N.I. 48.08.03

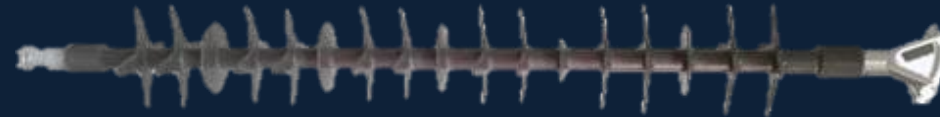

Totally Isolated Surface $\geq 1m$



NEW HIGH-SECURITY DEVELOPMENTS WITH LOW LEAKAGE CURRENT



GREATER PHASE-GROUND SAFETY DISTANCE IN ANCHOR CHAINS

Totally Isolated Surface $\geq 1,25m$



EXCLUSIVE MIXED *SHED* SYSTEM: DIELECTRIC FUNCTION + BIRD PERCHING DETERRENT FUNCTION

BIRD PROTECTION INSULATORS_ 15 up to 72,5kV



POLYMER AVIFAUNA INSULATOR CAON®-KORWI® Model C3670EBAV_AR .



INNOVATIVE SOLUTIONS FOR NEW INSTALLATIONS _ 15-36kV / 70kN

Royal Decree 1432/2008 - BOJA 209 178/2006 - Ref. ENDESA 6709926 - TAM 300020 / GE AND012_4ªEd.



EXCLUSIVE MIXED SHEDS SYSTEM : DIELECTRIC FUNCTION + BIRD PERCHING DETERRENT FUNCTION





IMPROVED FEATURES AND PERFORMANCE. DESIGN EVOLUTION.



C3670EBAV C3670EBV_AR

- The C3670EBAV_AR Model is an evolution of the CAON®-KORWI® C3670EBAV insulator:

This revolutionary design is based on the morphological guidelines provided by the technicians of the Biodiversity and Natural Environment Department of one of the Autonomous Communities with the highest number of protected species, and is part of the evolution of the C3670EBAV Model (over 35.624 units installed in Spain, with zero recorded incidents), to which 12 star-shaped sheds have been added to provide the insulator with ADDITIONAL PERFORMANCE features, such as turning it into a BIRD PERCHING DETERRENT.

- Excellent Dielectric Performance:

INSULATOR suitable for MEDIUM VOLTAGE LINES UP TO 36 kV with a Specified Mechanical Load of 70 kN.

- Leakage Path Design with LEVEL IV:

A contained Leakage Path has been achieved to avoid overprotection of the network, simulating between the diameter of the sheds and the fully insulated length provided by this insulator (> 1 m). The result is an insulator with a leakage path of 1,350 mm, - VERY HIGH POLLUTION - AND012, Ed. 4/2015 -, and a Protected Leakage Path > 1,000 mm.

REGULATIONS AND APPROVALS

Design in accordance with the UNE-EN 61109:2010 Standard (IEC 61109:2008).

The CAON®-KORWI® C3670EBAV_AR insulator has been the first of its kind to be approved by an Electric Company, in this case, ENDESA DISTRIBUCION, in accordance with its regulations GE AND012-4th Ed, and has been an Approved Material since 23/06/2015, belonging to SIE Code No. 6709926 – TAM 300020.

Great ease of INSTALLATION AND MAINTENANCE _ Reduction of associated costs

- SINGLE-PIECE INSULATOR: Greater effectiveness against mechanical stresses and lower weight of the chain (3.16 kg), making transportation and installation easier (Vs. articulated chains).
- It is not necessary to cover the clips or the conductor, avoiding the appearance of moisture due to condensation and facilitating the detection of hot spots and faults in the cables.
- Auxiliary sheds in star shape protect the insulator against the harmful action of birds (crows) through their perch deterrent effect, also constituting a protective barrier for the 5 sheds that have a purely dielectric function.



IMPROVED FEATURES AND PERFORMANCE. MIXED SHEDS SYSTEM.



Protective function for BIRDS against electrocution.

CURRENT NATIONAL REGULATIONS FOR THE PROTECTION OF BIRDS AGAINST ELECTROCUTION (ROYAL DECREE 1432/2008) :

The guaranteed minimum safety distance between the end of the crossarm and the anchor clip – or the nearest live point – has a fully insulated length greater than 1 m. This distance is further ensured by the star-shaped sheds to prevent or hinder bird perching along the entire length of the insulator. Recent published tests determine that the anchor chains equipped with this insulator do not create extreme risk situations for birds.



• Detailed view of the design:



PERCH DETERRENT FUNCTION FOR BIRDS.

12 STAR-SHAPED SHEDS are interspersed along the insulator together with 5 sheds of purely dielectric function, forming an element designed to prevent or hinder bird perching:

- In the design conception of these 4-point star-shaped sheds, the nature and consistency of the material used for their manufacture have been meticulously studied, as well as the angles, radii, and thicknesses employed, to ensure they fulfill their perch deterrent function without posing any risk of entanglement or other dangers to birds.

IMPROVEMENT OF ELECTRICITY SUPPLY CONTINUITY

- These star-shaped sheds have been geometrically designed so as not to affect the dielectric performance of the insulator.
- They are larger in size - (the star is inscribed in a circle of 130mm) - than the dielectric sheds, to fulfill the ANTI-PERCH DETERRENT function and to protect the dielectric sheds from the attack of birds like corvids, forming a protective barrier for the 5 purely dielectric sheds, thus improving the continuity of electric supply.

C3670EBAV_AR



POLYMERIC INSULATOR CAON-KORWI® C3670EBAV_AR. TECHNICAL DATA SHEET.



C3670EBAV_AR

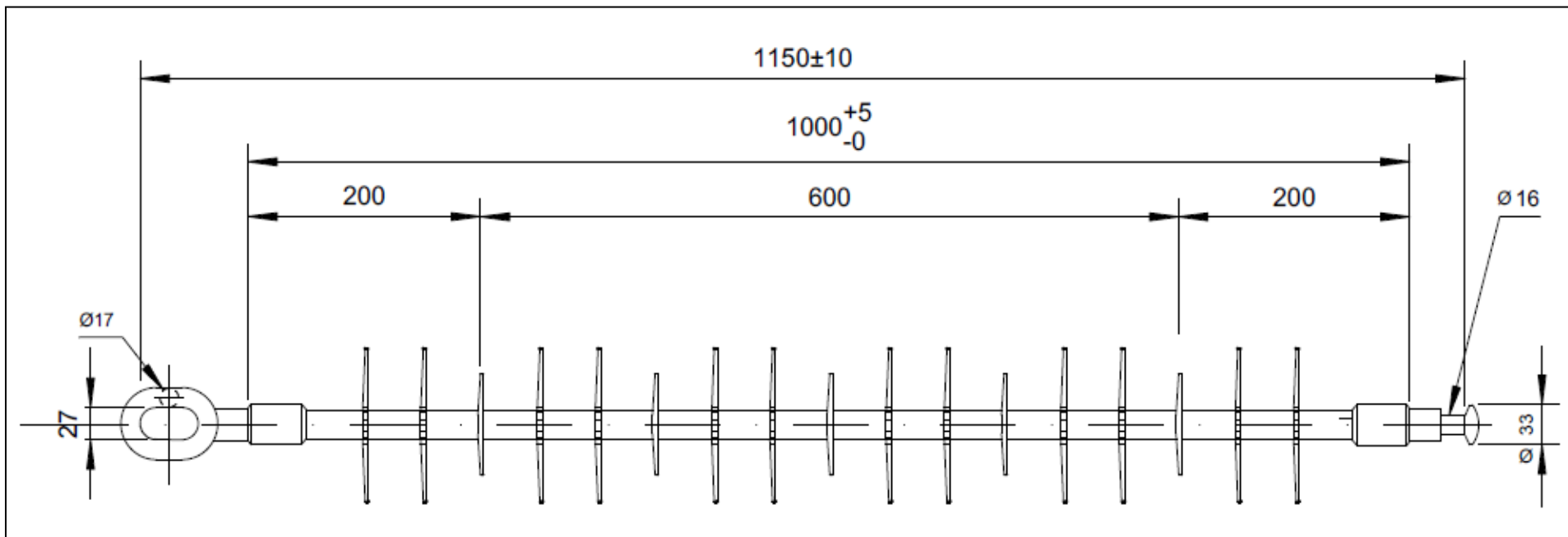

Type Mod.	Service Voltage	Creepage Distance	Dry Arc	CME Mechanic Charge	Test Voltages	
					1,2/50 BIL	50 Hz/ WET
CAON-KORWI C3670EBAV_AR	kV	mm	mm	kN	kV	kV
	36	1350	1005	70	200	80

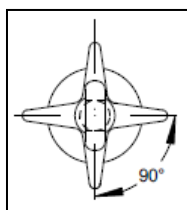

Weights of Insulators and Complete Chains		Surface *
Insulator C3670EBAV_AR		1,92 kg / 0,0394 m ²
Anchor Chain LA-56 (GA-1)		3,16 kg / 0,0507 m ²
Anchor Chain LA-110 (GA-2)		3,94 kg / 0,0579 m ²

* Use in wind resistance calculations



POLYMERIC INSULATOR CAON-KORWI® C36100EBAV_AR. TECHNICAL DATA SHEET.



C36100EBAV_AR

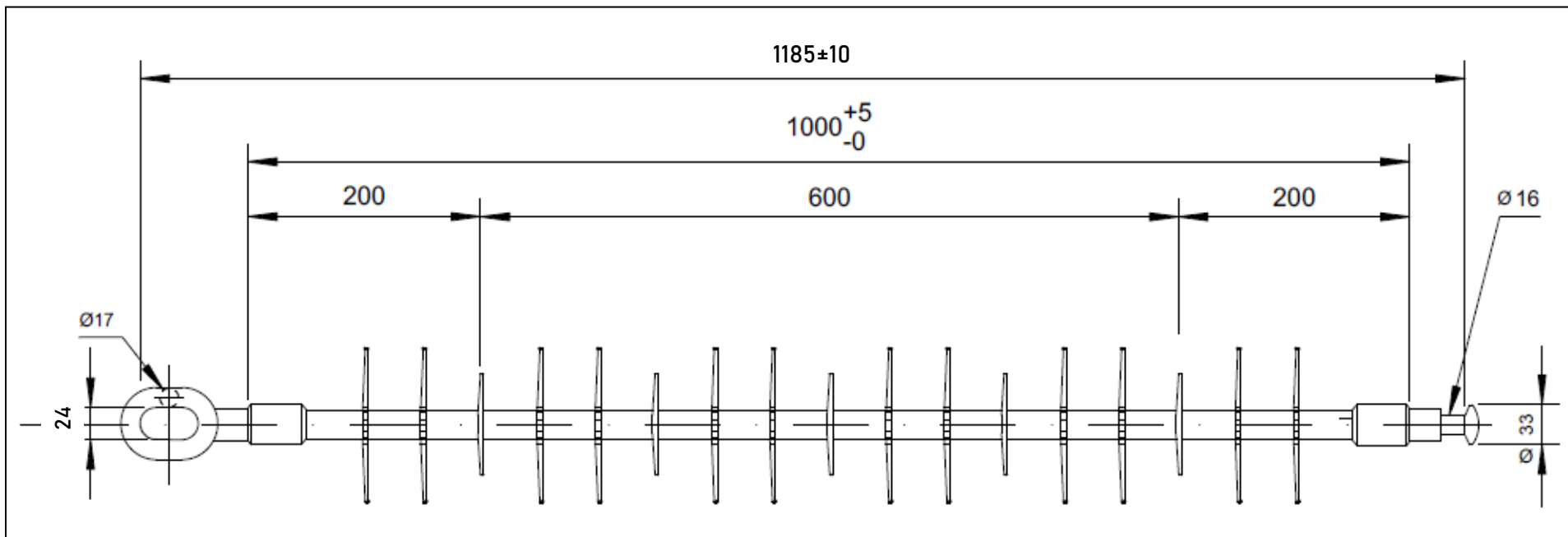

Type Mod.	Service Voltage	Creepage Distance	Dry Arc	CME Mechanic Charge	Test Voltages	
					1,2/50 BIL	50 Hz/ WET
CAON-KORWI C36100EBAV_AR	kV	mm	mm	kN	kV	kV
	36	1350	1005	100	200	80

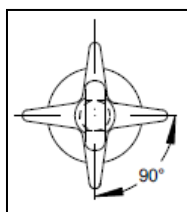

Weights of Insulators and Complete Chains		Surface *
Insulator C36100EBAV_AR	2,10 kg	0,0406 m ²
Anchor Chain LA-56 (GA-1)	3,34 kg	0,0522 m ²
Anchor Chain LA-110 (GA-2)	4,12 kg	0,0596 m ²

* Use in wind resistance calculations





MV / HV NETWORKS AVIFAUNA PROTECTION SYSTEMS 15kV – 72,5kV



> 95.000 Units Installed 2015 - 2024



MATERIALS, PERFORMANCE, AND ADDED VALUE. PROVEN PERFORMANCE.

COMPONENTS AND MATERIALS

INSULATING CORE: Epoxy resin reinforced with fiberglass - Acid resistant - High capacity under mechanical stress (70kN).

- CONTINUOUS SILICONE ENVELOPE TYPE HTV WITH HYDROPHOBIC LEVEL Hc2: Due to its composition and nature, it repels moisture accumulation. This insulator is equipped with a minimum silicone thickness of 4.5mm, which provides exceptional performance in very high contamination areas.
- METAL HARDWARE: The thickness of the zinc (Zn) coating on the hardware -EYE/BALL- has been reinforced to 120 µm, in accordance with standard EN 60383-1.

ADDED VALUE ENVERTEC

- DESIGN 100% EnverTec S.L. (Granada – Spain).
- Detailed specification of each manufacturing batch.
- Monitoring of the production process of the insulators. Traceability Warranty.
- Extended quality control:
 - Testing in an independent accredited laboratory of the polymeric material of the envelope used in each batch.
 - Individual and sampling tests in accordance with UNE-EN 61109:2010 and the criteria of ISO 17025.
- Report of QUALITY AND TRACEABILITY EVALUATION for each batch of insulators supplied.

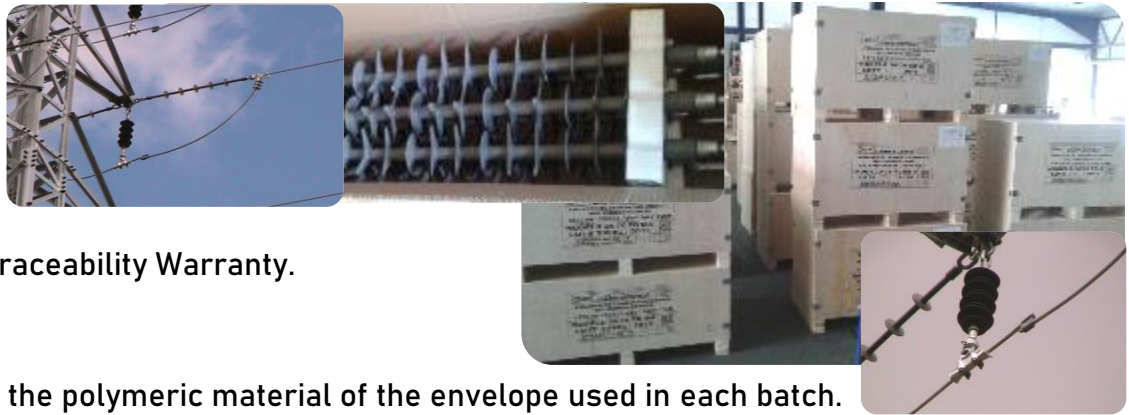

C3670EBAV_AR



COMPLIANCE WITH ANTI-ELECTROCUTION REGULATIONSTHROUGH DISTANCE + INSULATION = TOTAL LENGTH FULLY INSULATED.

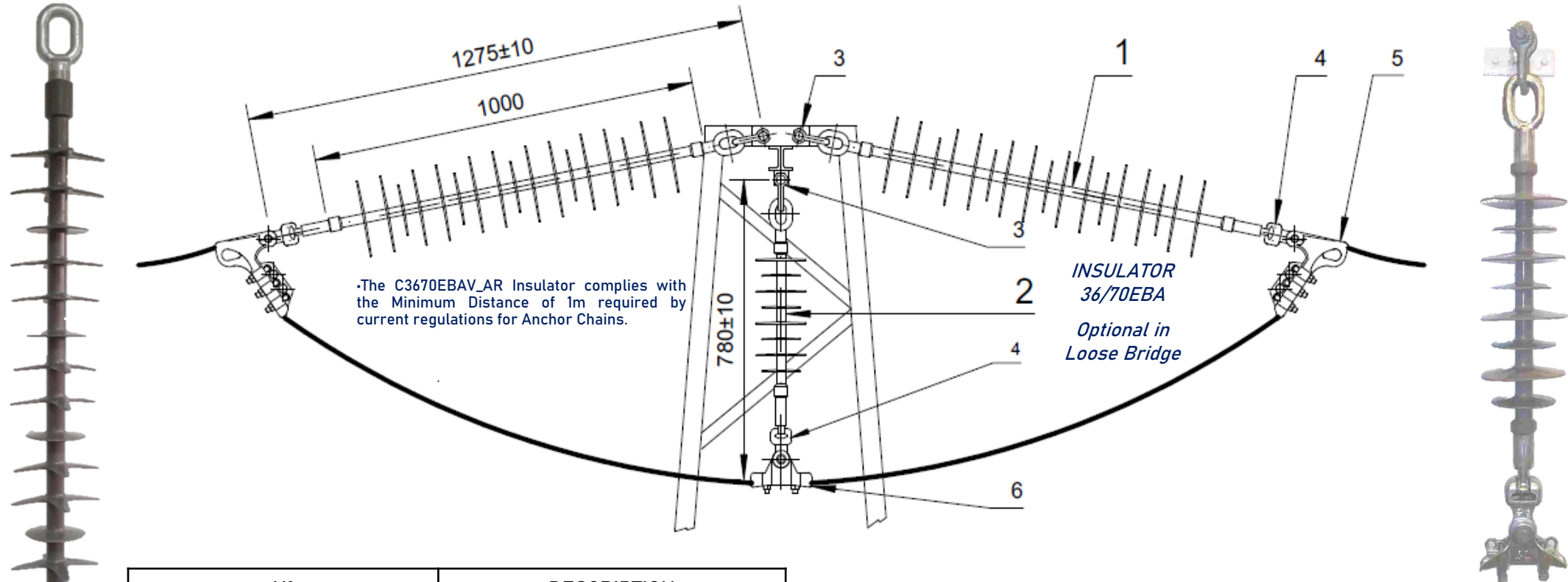

The C3670EBAV_AR Insulator complies with the Minimum Distance of 1m required by current regulations for Anchor Chains.

INSULATOR
36/70EBA
Optional in
Loose Bridge

Nº	DESCRIPTION
1	C3670EBAV_AR INSULATOR
2	C3670EBA INSULATOR
3	GN CONNECTOR
4	R-16 JOINT
5	ANCHOR CLAMP
6	SUSPENSION CLAMP

- SINGLE-BODY CHAIN - WITHOUT METAL EXTENSIONS
- CONTINUOUS POLYMERIC INSULATION
- GREATER EASE OF ASSEMBLY - NON-ARTICULATED
- LOWER WEIGHT: 3.16 Kg vs. 11.6 Kg.
- EASY DETECTION OF HOT SPOTS - FAULTS
- ECONOMICALLY VERY COMPETITIVE

Chain Ref.
CAD36PGS
Alignment

Brand 2: The 36/70EBA Insulator meets the Minimum Distance of 0.75 m required by current regulations in Suspension/Alignment Chains.

C3670EBAV_AR





SUSPENSION-ALIGNMENT CHAINS 24-36kV. DISTANCE ENSURED >750mm.

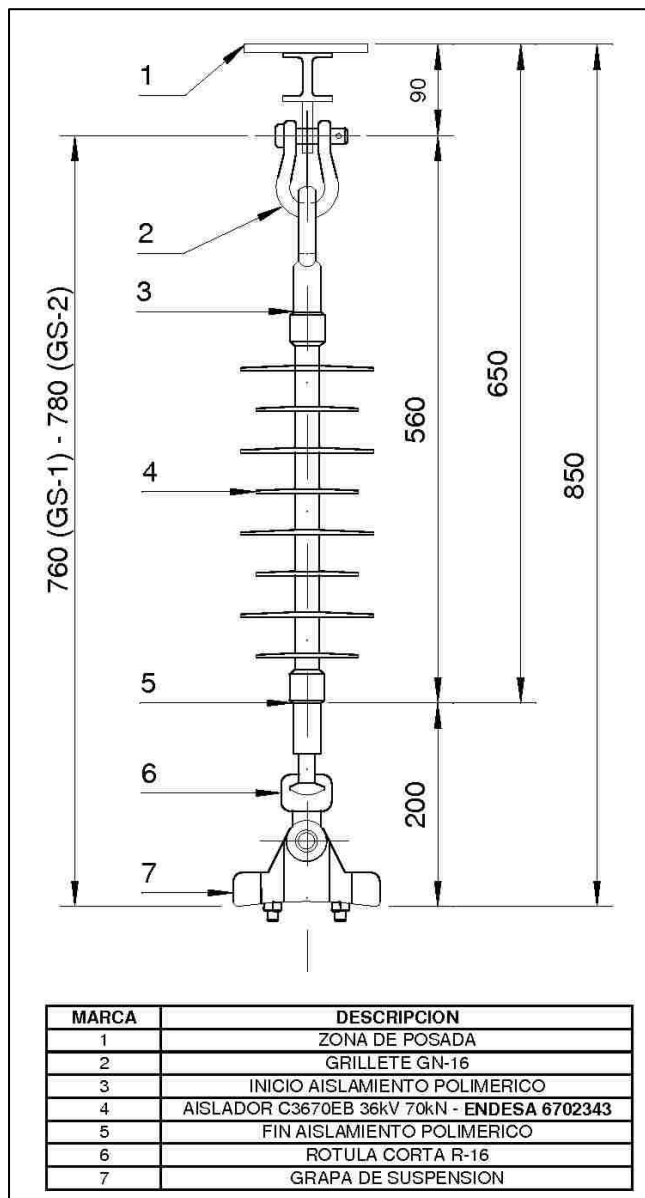

Complete Chain
Ref. CAD36PGS
Alignment

SUSPENSION CHAIN CAD36PGS - WITH INSULATOR Model 36/70EB A - 36 kV
70kN - ENDESA STANDARD GE-AND012 / Endesa Code 6702343 - TAM 300032

The CAD36PGS chain provides a distance greater than 0.75 m from the conductor to the anchor shackle at the crossarm, as required by current regulations for Suspension/Alignment Chains.

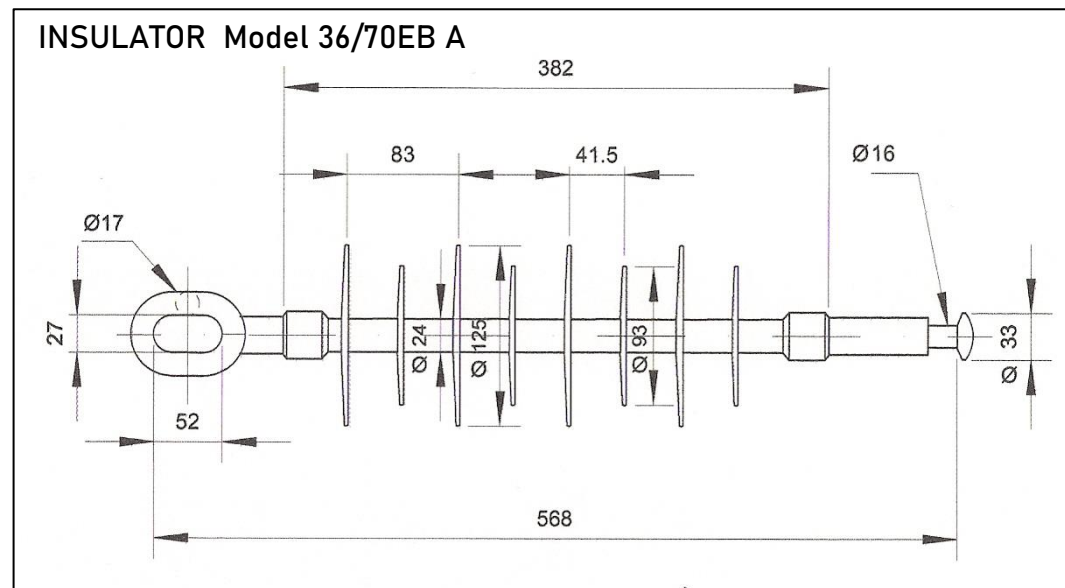

Type Mod.	Service Voltage	Creepage Distance	Dry Arc	CME Mechanic Charge	Test Voltages	
					1,2/50 BIL	50 Hz/ WET
CAON-KORWI C3670EBA	kV	mm	mm	kN	kV	kV
	36	980	415	70	170	70





BIRD PROTECTION SYSTEMS FOR 15kV- 132kV MV / HV GRIDS



CAON-KORWI® C3670EBAV_AR POLYMER INSULATOR. *IMAGE GALLERY.*

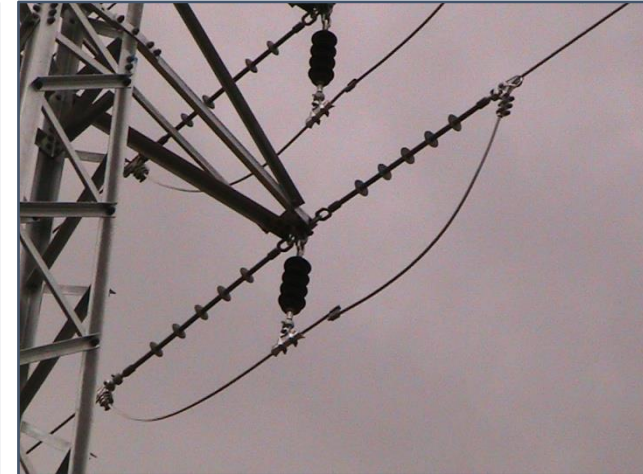

> 95.000 pcs
Installed
2015 - 2024

Installation Platform Prototype





POLYMER INSULATORS AS PER IBERDROLA 48.08.03:2018 STANDARDS *DATA SHEET.*



4803214

4803020

4803223

INSULATOR CODE 4803214

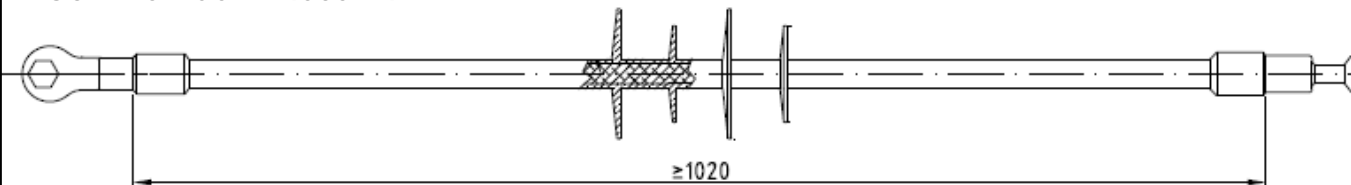

INSULATOR CODE C3670YBAV_AR

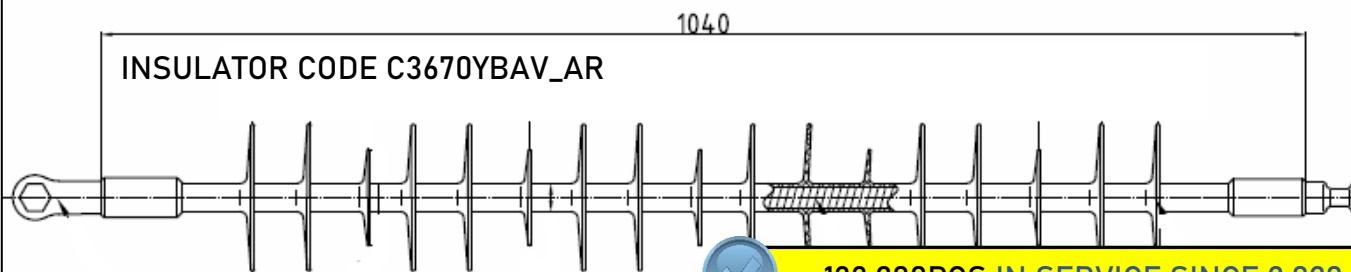

> 133.200PCS IN SERVICE SINCE 2.020

INSULATOR CODE 4803223

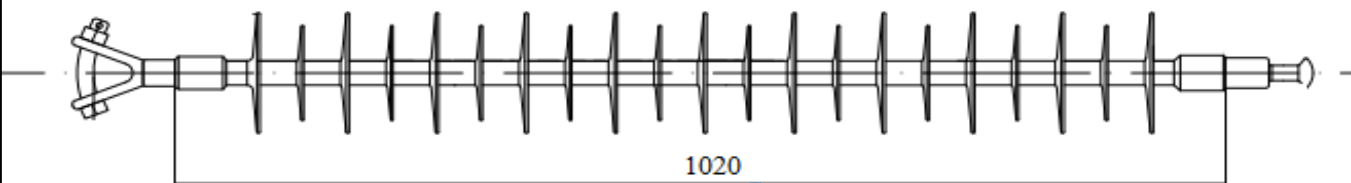

> 3.700PCS IN SERVICE SINCE 2.020

Model	Code	Rated Voltage (kv)	Leakage distance (mm)	Insulated length (mm)	Total length(mm)	Mechanical Load (kN)	Test Voltages(kv)	
							1,2/50 BIL	50Hz /Rain
U70YB30P_AL	4803214	30	1120	1020	1170	70	215	95
C3670YBAV_AR	4803020	30	1380	1040	1170	70	215	95
U70YB66P_AL	4803223	66	2250	1020	1170	70	380	165





CAON-KORWI® DIELECTRIC CORE BIRD PROTECTION INSULATORS

ANTI-ELECTROCUTION MEASURES FOR 15-132kV / 70-120kN LINES

ACQUIREMENT OF PHASE-EARTH SAFETY DISTANCE IN DEAD END STRINGS BY \geq
1,25m. LONGITUDINALLY INSULATED SURFACE

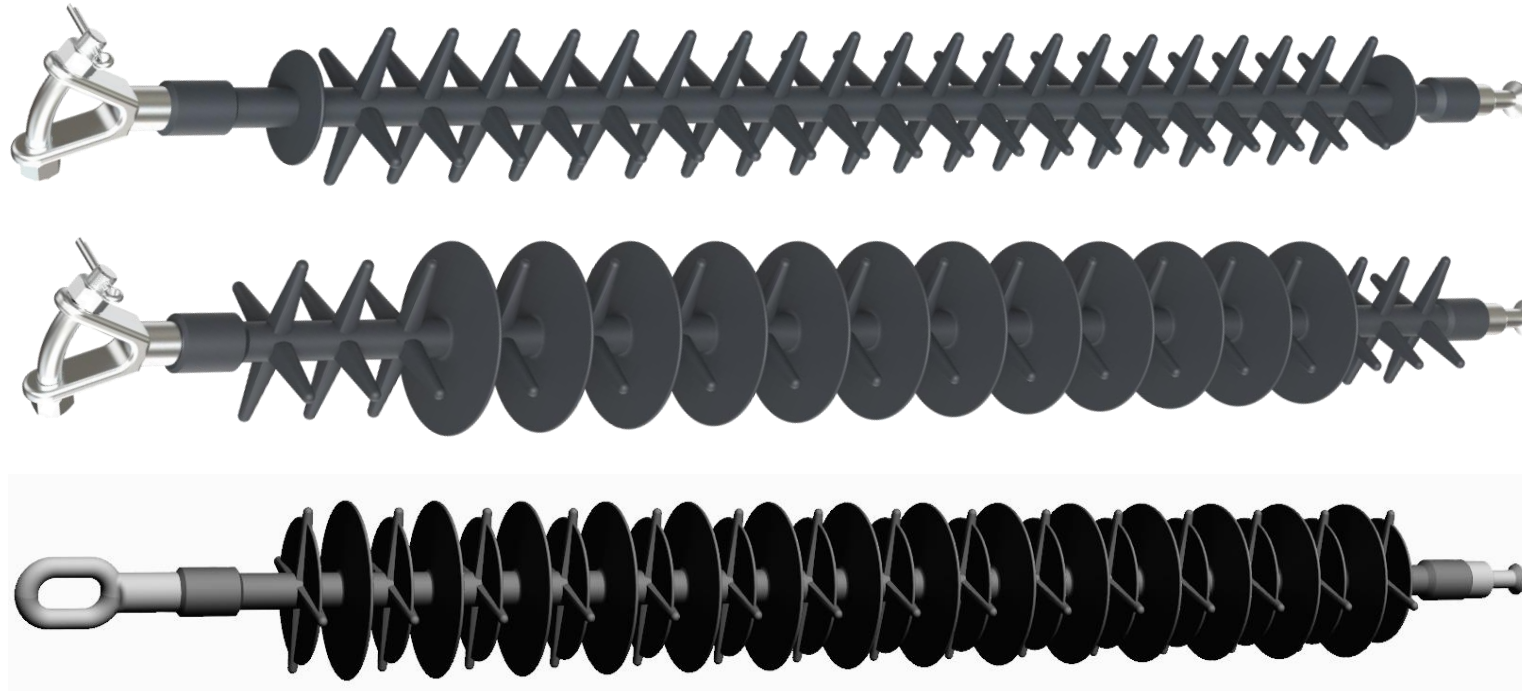

Models U70YB30P_ALA / U70YB66P_ALA / C132120EBAV_AR

Combination of functions: Dielectric and bird perching deterrent

INSULATED DEADEND STRINGS WITH BIRD PERCHING DETERRENT.





BIRD PROTECTION SYSTEMS STRUCTURAL SOLUTIONS

1st, 2nd AND 3rd CATEGORY NETWORKS

DEVELOPMENT PRESENTATION . INSULATED DISTANCE WITH BIRD PERCHING DETERRENT

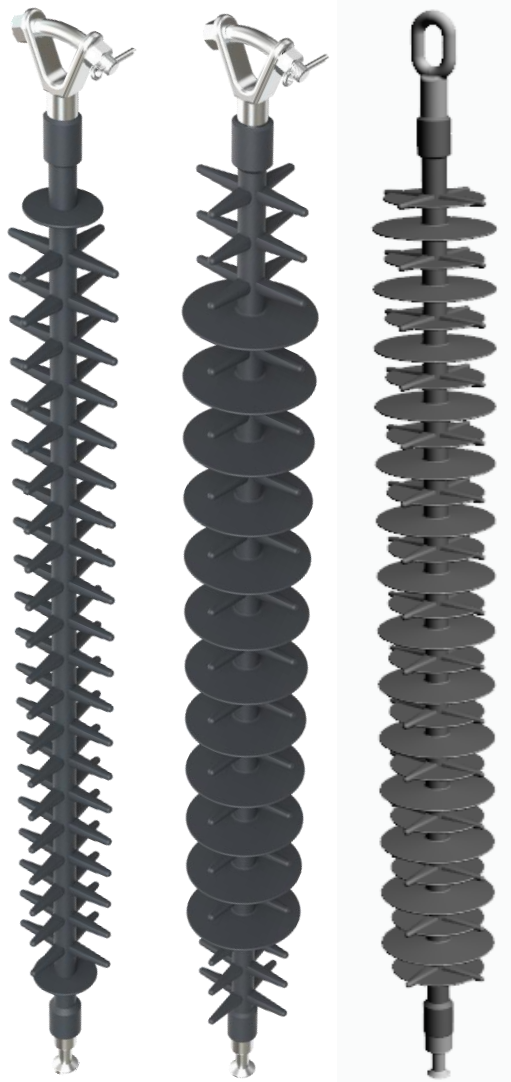

U70YB30P_ALA
U70YB66P_ALA

C132120EBAV_AR

AIM.

The aim of the present development is to present two models of one-piece Insulator with $\geq 1,25\text{m}$ longitudinally insulated surface, both fitted with Bird Perching Deterrent Elements with a Specific Design, and with 70kN SML (Specified Mechanical Load). Allowing it to be used in deadend strings in the most usual bare conductors.

LAW

RD.1432/2008_ Natural Heritage and Biodiversity Law (42/2007). Environmental Responsibility Law (26/2007) _ Law 21/1992 - Art.9 _ Law 24/2013-Art. 53.9.

REGULATIONS.

UNE-EN 61109:2008, "Insulators for overhead lines- Composite suspension and tension insulators for a.c. systems with a nominal voltage greater than 1000 V - Definitions, test methods and acceptance criteria."

UNE 60060-1:2012, "High-voltage test techniques-Part 1: General definitions and test requirements".

SCOPE AND FIELD OF APPLICATION.

Lines present in Transmission and Distribution Networks: 1st Category ($>66\text{kV}$ and $<220\text{kV}$), 2nd Category ($>30\text{kV}$ and $\leq 66\text{kV}$), and 3rd Category ($>1\text{kV}$ and $\leq 30\text{kV}$).

TRACK RECORD OF DESIGN.

This design by ENVERTEC S.L. is an evolution of model C3670EBAV2 and C3670EBAV_AR1, adding together more than 53.500 units installed in Spain with zero incidents since 2012.

STRUCTURAL SOLUTION.

The presented models constitute a structural solution guaranteeing a Phase-Earth safety distance fully insulated $\geq 1,25\text{m}$, between the end of the crossarm and the deadend clamp, obtained thanks to the dielectric core and the continuous surface insulating coating of a polymeric nature which they incorporate.



1. 2.

1. C3670EBAV_AR Model : 2.015

2. C3670EBAV Model : 2.012





MODEL U70YB30P_ALA INSULATED . DIMENSIONS , PARTS AND MATERIALS.

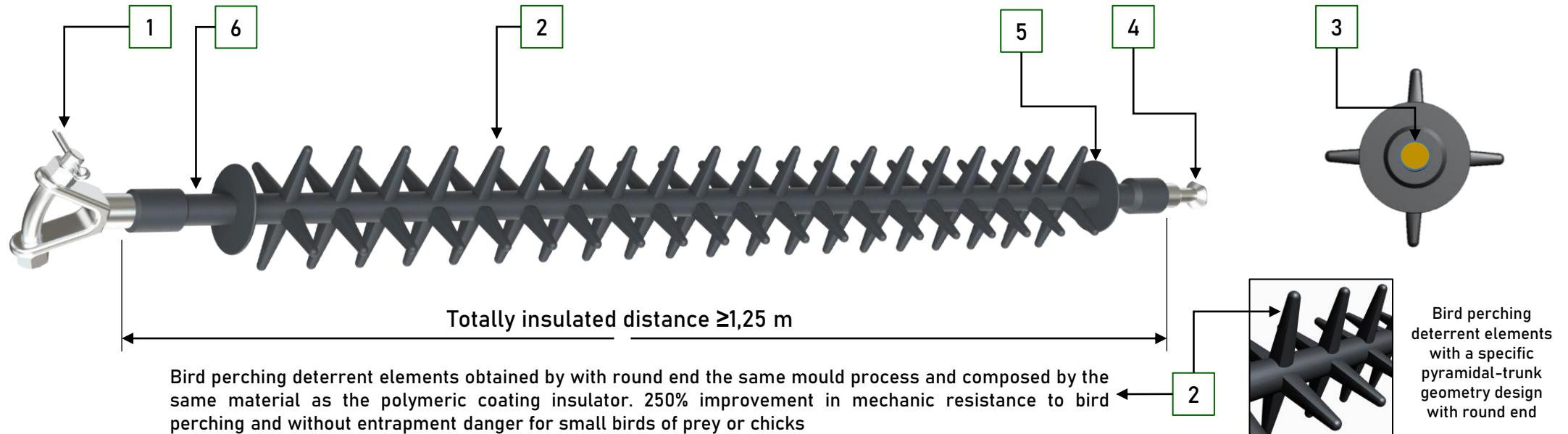

1.
Fork 16 Standard.
(IEC60120 - 16)
120 μ m hot galvanized forged Steel. Docking on structure side.
It is posible to provide the insulator with Type E24 Ring - Standard *GSC0010 ENEL*.

2.
20 lines with 4 bird perching deterrent elements each one. The deterrents have 51 mm minimun height and they are inscribed in a 130 mm circumference. The lines distance is 50mm as a máximo.
Standard GSC0010 ENEL

3.
Dielectric core, produced with Epoxy resin, reinforced by glass fibre and resistant to hydrolysis and acids. High electric insulated efficacy and 70 kN mechanical charge.
4. Ball Joint 16 Standard (IEC60120 - 16) 120 μ m forged and galvanized Steel.

5. Circular Sheds (2units) Dielectrical Function-Standard *NI 48.08.03. I-DE*.
The insulator design has been adjusted to offer type "e" level leakage- IEC 60815- Suitable for high pollution areas offering ≤ 1350 mm value -Standard *GSC0010 ENEL*.

6. POLYMERIC COATING TECHNICAL FEATURES	
Flammability	V0 (UNE 60695-11-10)
Density	>1,1 g/cm 3 (ISO-868)
Strength	>60 Shore A (ISO-868)
Tensile Strength	>4N/mm 2 (EN 60811-501)
Elasticity Modulus	>200% (EN 60811-501)
Tear Resistance	>12N/mm 2 (UNE-HD-605)
Dielectric Strenght	>18kV/mm (UNE 60243-1)
Ozone Resistance	250ppm (UNE 60811-403:2012)
Accelerated Weathering	1000h UNE 211605



MODEL U70YB66P_ALA INSULATED . DIMENSIONS , PARTS AND MATERIALS.

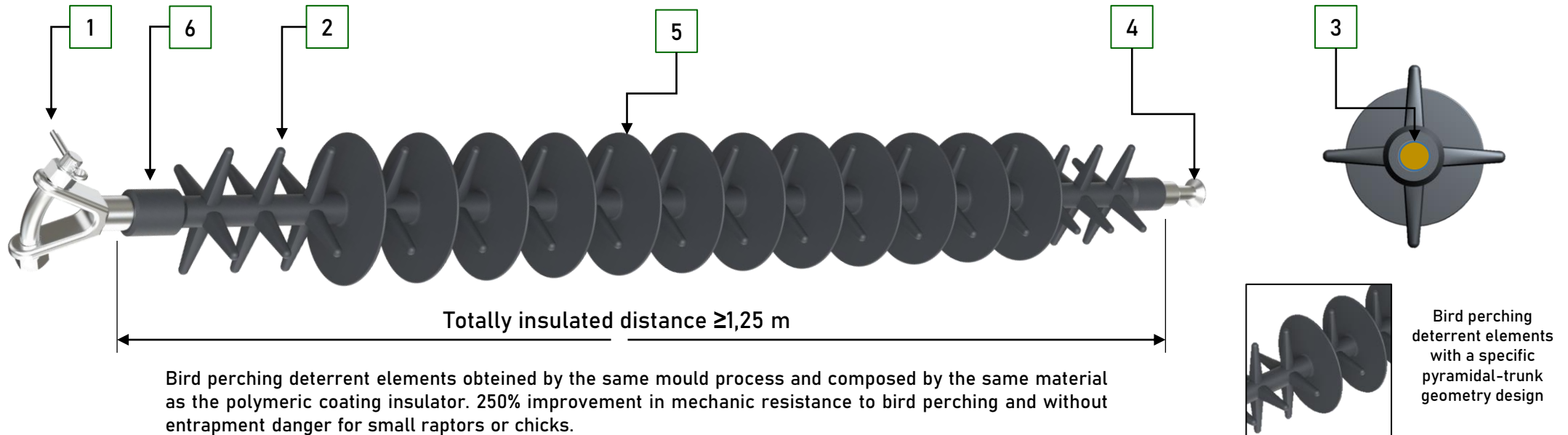

Bird perching deterrent elements obtained by the same mould process and composed by the same material as the polymeric coating insulator. 250% improvement in mechanic resistance to bird perching and without entrapment danger for small raptors or chicks.

1.
Fork 16 Standard.
(IEC60120 - 16)
120µm hot galvanized forged Steel. Docking on support side.
It is posible to provide the insulator with S16 Coupling - Standard *GSCH004 ENEL*.

2.
17 lines with 4 bird perching deterrent elements each one. The deterrents have 51 mm minimun height and they are inscribed in a 130 mm circumference. The line distance is 50mm as a máximo.

3.
Dielectric core, produced with Epoxy resin, reinforced by glass fibre and resistant to hydrolysis and acids. High electric insulated efficacy and 70 kN mechanical charge.

4. Ball Joint 16 Standard.
(IEC60120 - 16) forged and galvanized Steel 120µm.

5. Circular Sheds (12ud) Dielectrical Function. The insulator design has been adjusted to offer type "e" level leakage- IEC 60815- Suitable for high pollution áreas offering ≥ 2250 mm value -Standard *GSCH004 ENEL - Standard NI 48.08.03 I-DE*.

6. POLYMERIC COATING TECHNICAL FEATURES	
Flammability	V0 (UNE 60695-11-10)
Density	>1,1 g/cm 3 (ISO-868)
Strength	>60 Shore A (ISO-868)
Tensile Strength	>4N/mm 2 (EN 60811-501)
Elasticity Modulus	>200% (EN 60811-501)
Tear Resistance	>12N/mm 2 (UNE-HD-605)
Dielectric Strenght	>18kV/mm (UNE 60243-1)
Ozone Resistance	250ppm (UNE 60811-403:2012)
Accelerated Weathering	1000h UNE 211605



MODEL C132120EBAV_AR INSULATED . DIMENSIONS , PARTS AND MATERIALS.

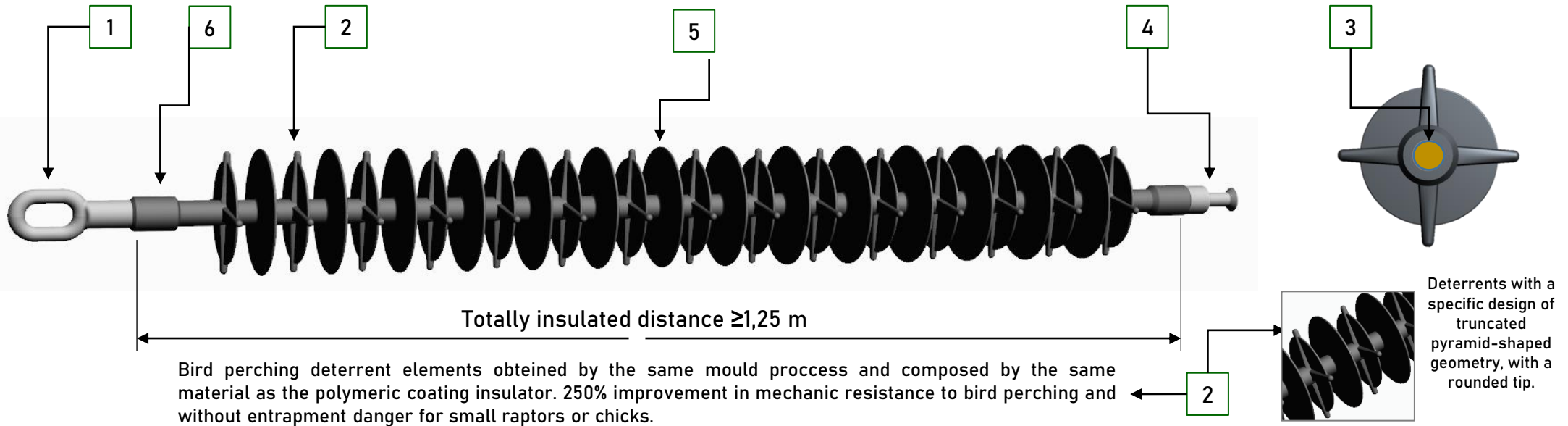

Bird perching deterrent elements obtained by the same mould process and composed by the same material as the polymeric coating insulator. 250% improvement in mechanic resistance to bird perching and without entrapment danger for small raptors or chicks.

1.
Ring Standard 24.
(IEC61466 - 24)
120µm hot galvanized forged Steel. Docking on support side

2.
15 fins with 4 bird perching deterrent elements each one. The deterrents have 51 mm minimum height and they are inscribed in a 130 mm circumference. The line distance is 50mm as a maximum.

3.
Dielectric core, produced with Epoxy resin, reinforced by glass fibre and resistant to hydrolysis and acids. High electric insulated efficacy and 120 kN mechanical charge.

4. Ball Joint 16 Standard.
(IEC60120 - 16) forged and galvanized Steel 120µm

5. Circular Sheds (14ud) Dielectrical Function. The insulator design has been adjusted to offer type "d" level leakage- IEC 60815- Suitable for high pollution areas offering ≥ 3652mm value.

6. POLYMERIC COATING TECHNICAL FEATURES	
Flammability	V0 (UNE 60695-11-10)
Density	>1,1 g/cm 3 (ISO-868)
Strength	>60 Shore A (ISO-868)
Tensile Strength	>4N/mm 2 (EN 60811-501)
Elasticity Modulus	>200% (EN 60811-501)
Tear Resistance	>12N/mm 2 (UNE-HD-605)
Dielectric Strength	>18kV/mm (UNE 60243-1)
Ozone Resistance	250ppm (UNE 60811-403:2012)
Accelerated Weathering	1000h UNE 211605



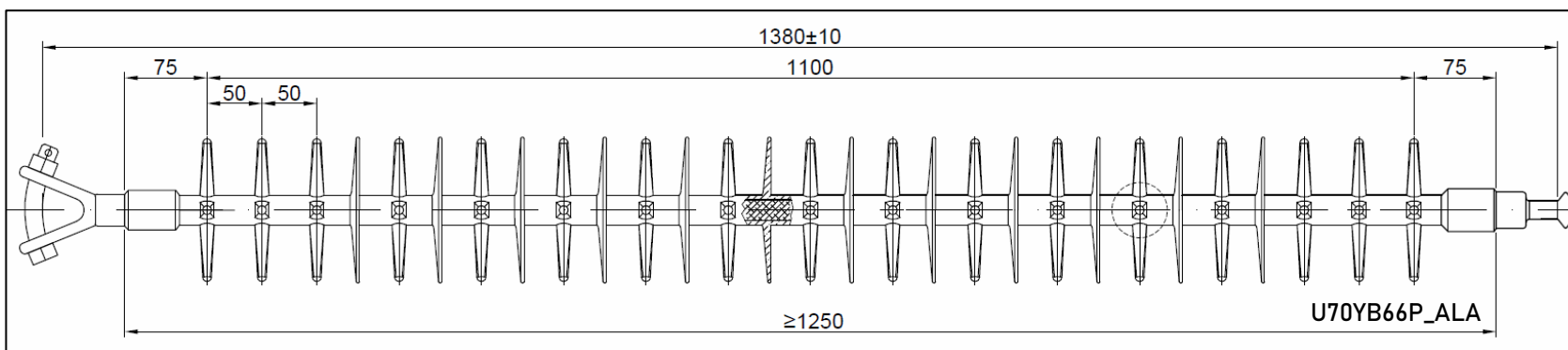
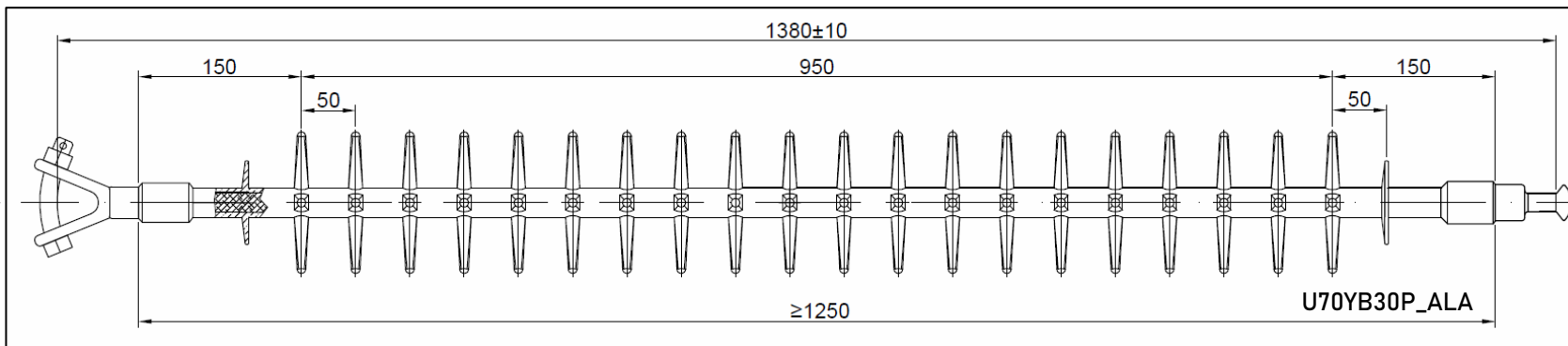
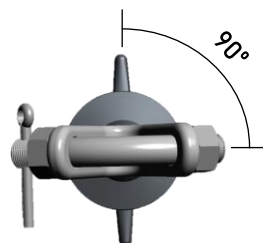

U70YB30P_ALA		COLOUR_COLOR	GRAY_GRIS
STANDARD_NORMA		IEC61109	
DRY ARCING DISTANCE_DISTANCIA DE ARCO		1250mm	
CREEPAGE DISTANCE_LINEA DE FUGA		1350mm	
ROUTINE TEST LOAD (RTL)		35kN	
CARGA MECANICA DE Routine		35kN	
SPECIFIED MECHANICAL LOAD(SML)		70kN	
CARGA MECANICA ESPECIFICADA(CME)		70kN	
TORSION STRENGTH _MOMENTO DE TORSION		6 daN.m	
Ur / Umax.		30kV/36kV	
BASIC IMPULSE LEVEL (BIL)		215kV	
NIVEL BASICO DE IMPULSO(NBI)		215kV	
POWER FREQUENCY WITHSTAND		DRY_SECO	110kV
TENSION ENSAYO A F.I.		WET_LLUVIA	95kV

U70YB66P_ALA		COLOUR_COLOR	GRAY_GRIS
STANDARD_NORMA		IEC61109	
DRY ARCING DISTANCE_DISTANCIA DE ARCO		1250mm	
CREEPAGE DISTANCE_LINEA DE FUGA		2425mm	
ROUTINE TEST LOAD (RTL)		35kN	
CARGA MECANICA DE Routine		35kN	
SPECIFIED MECHANICAL LOAD(SML)		70kN	
CARGA MECANICA ESPECIFICADA(CME)		70kN	
TORSION STRENGTH _MOMENTO DE TORSION		6 daN.m	
Ur / Umax.		66kV/72,5kV	
BASIC IMPULSE LEVEL (BIL)		380kV	
NIVEL BASICO DE IMPULSO(NBI)		380kV	
POWER FREQUENCY WITHSTAND		DRY_SECO	180kV
TENSION ENSAYO A F.I.		WET_LLUVIA	165kV



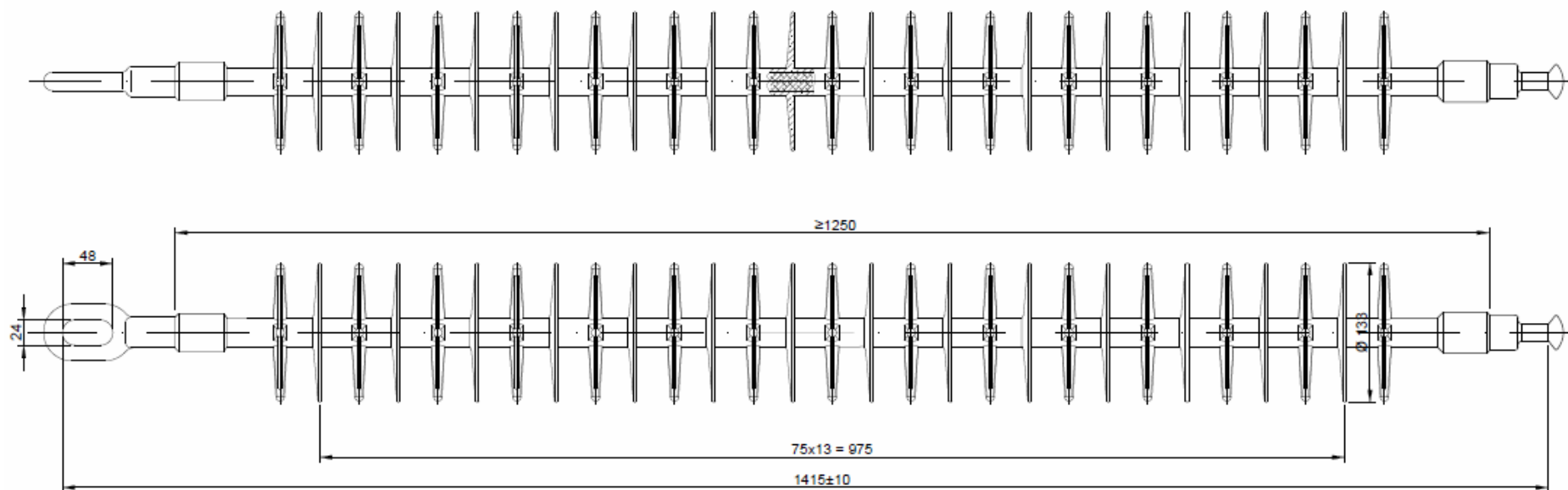

C132120EBAV_AR	COLOUR_COLOR	GRAY_GRIS
STANDARD_NORMA	IEC61109	
DRY ARCING DISTANCE_DISTANCIA DE ARCO	1250mm	
CREEPAGE DISTANCE_LINEA DE FUGA	3700mm	
ROUTINE TEST LOAD (RTL)	60kN	
CARGA MECANICA DE Routine	60kN	
SPECIFIED MECHANICAL LOAD(SML)	120kN	
CARGA MECANICA ESPECIFICADA(CME)	120kN	
TORSION STRENGTH_MOMENTO DE TORSION	6 daN.m	
Ur / Umax.	132kV/145kV	
BASIC IMPULSE LEVEL (BIL)	675kV	
NIVEL BASICO DE IMPULSO(NBI)	675kV	
POWER FREQUENCY WITHSTAND	DRY_SECO	380kV
	TENSION ENSAYO A F.I.	WET_LLUVIA 320kV

POLYMERIC COATING TECHNICAL FEATURES	
Flammability	V0 (UNE 60695-11-10)
Density	>1,1 g/cm 3 (ISO-868)
Strength	>60 Shore A (ISO-868)
Tensile Strength	>4N/mm 2 (EN 60811-501)
Elasticity Modulus	>200% (EN 60811-501)
Tear Resistance	>12N/mm 2 (UNE-HD-605)
Dielectric Strengh	>18kV/mm (UNE 60243-1)
Ozone Resistance	250ppm (UNE 60811-403:2012)
Accelerated Weathering	1000h UNE 211605

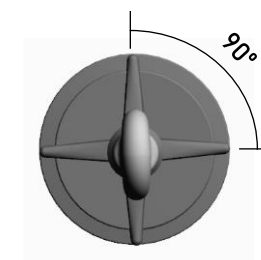



IMPROVED PERFORMANCE. REDUCTION OF ASSOCIATED COSTS.

EASE OF INSTALLATION AND REDUCTION OF MAINTENANCE COSTS

- SINGLE-PIECE INSULATORS.
 - They do not require auxiliary deterrent elements that may pose a risk of entrapment for birds or reduce the insulator's performance due to exposure to climatic aging or that may detach during their useful life.
 - Higher effectiveness against mechanical stresses with lower weight of the complete chain, facilitating transportation and installation, compared to articulated chains made of glass or polymeric materials equipped with extensions with a metallic core.
 - Greater aerodynamic efficiency compared to articulated chains equipped with extensions featuring "anti-perching" devices or "anti-perching spirals."
 - Continuous HTV silicone sheath _ Hc2: Due to its composition and nature, it repels moisture accumulation (ice sleeves), registering lower leakage currents, which provides greater long-term safety against the risk of decreased creepage distance, thus avoiding electrocution risks, thanks to the hydrophobicity imparted to the contaminant layer.
 - The climatic aging tests of 5,000 hours conducted at the STRI laboratory in Sweden on the polymeric sheath, according to Annex C of IEC 61109, allow us to estimate the useful life of these insulators for a minimum period of 20 years.

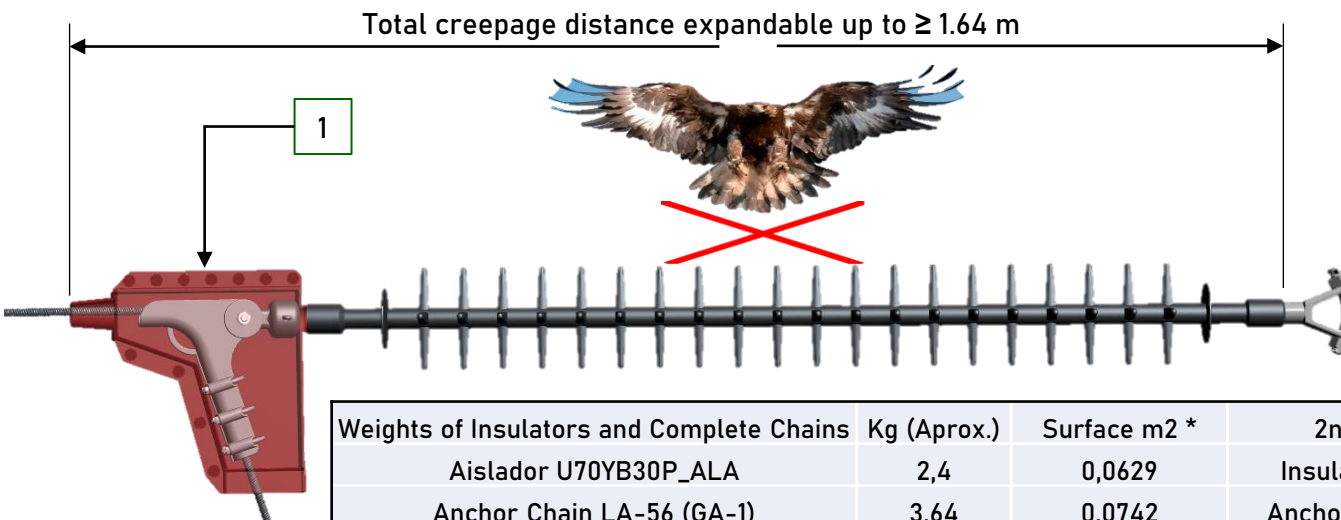

INCREASE IN PHASE-TO-GROUND DISTANCE IN TERRITORIES THAT REQUIRE IT

The U70YB30P_ALA and U70YB66P_ALA insulators have been designed to be fully compatible with the ENVERTEC®_CAON-KORWI® Model STSC silicone avifauna protection covers, increasing the longitudinally insulated surface to 1.64 m by covering the stem, socket, and anchor.

(*) Used in wind resistance calculations.

Weights of Insulators and Complete Chains	Kg (Aprox.)	Surface m2 *	2nd Category Lines	Kg (Aprox.)	Surface m2 *
Aislador U70YB30P_ALA	2,4	0,0629	Insulator U70YB66P_ALA	4,43	0,0670
Anchor Chain LA-56 (GA-1)	3,64	0,0742	Anchor Chain LA-56 (GA-1)	5,67	0,0783
Anchor Chain LA-110 (GA-2)	4,42	0,0814	Anchor Chain LA-110 (GA-2)	6,45	0,0855



INSULATOR Model U70YB30P_ALA . INSTALLATION AND MEASUREMENTS ON SUPPORT.



U70YB30P_ALA

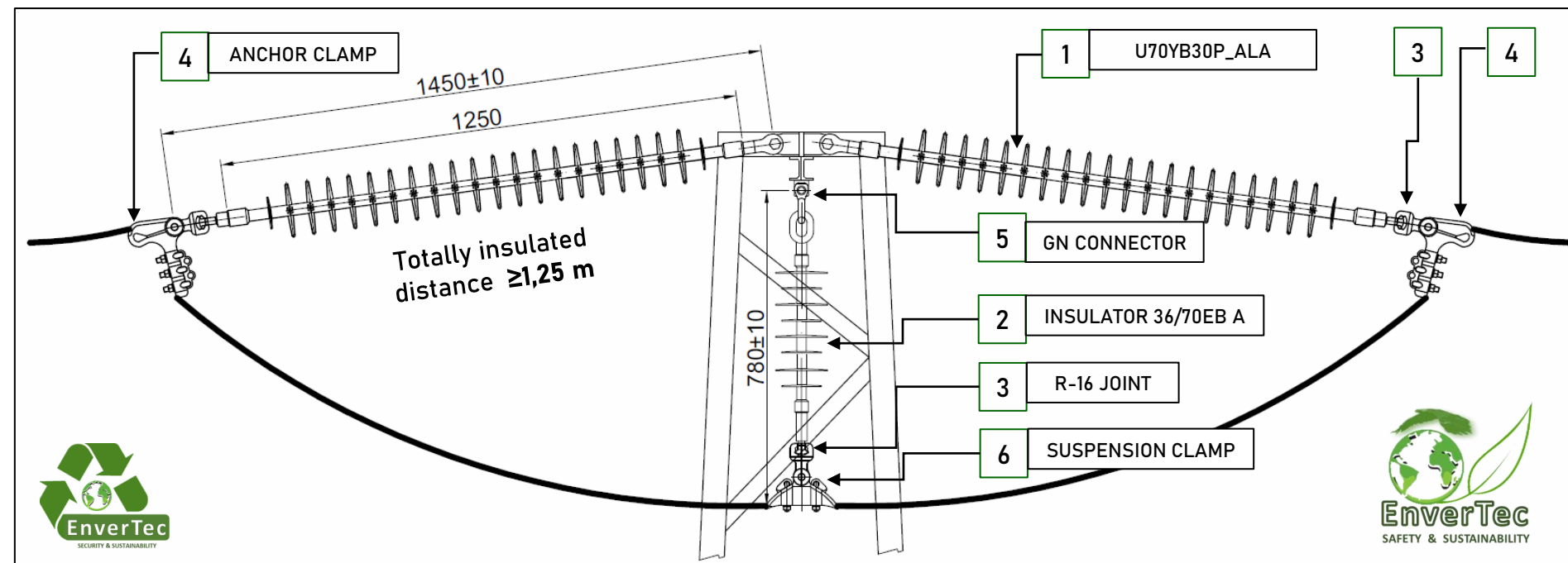

- 100% DESIGN BY ENVERTEC S.L. (Granada – Spain).
- Technical specifications and production process monitoring for each batch of insulators.
- Batch Traceability Warranty:
 - Permanent embossed marking with Batch Number and Manufacturing Date.
 - Individual and sample testing according to UNE-EN 61109:2008
 - Quality documentation subject to ISO 17025 standards.

DESIGNED TO PROTECT DIFFERENT WINGSPANS



- Bonelli's Eagle
- Golden/Imperial Eagle
- Bearded Vulture , ...



- Griffon Vulture
- Black Vulture
- Owls , Barn Owls , ...

Mark [2]
The 36/70EBA Insulator complies with the Minimum Distance of 0.75 m required by current regulations for Suspension/A lignment Chains.





SUSPENSION/ALIGNMENT CHAINS 24-36kV. DISTANCE ENSURED >0.75m

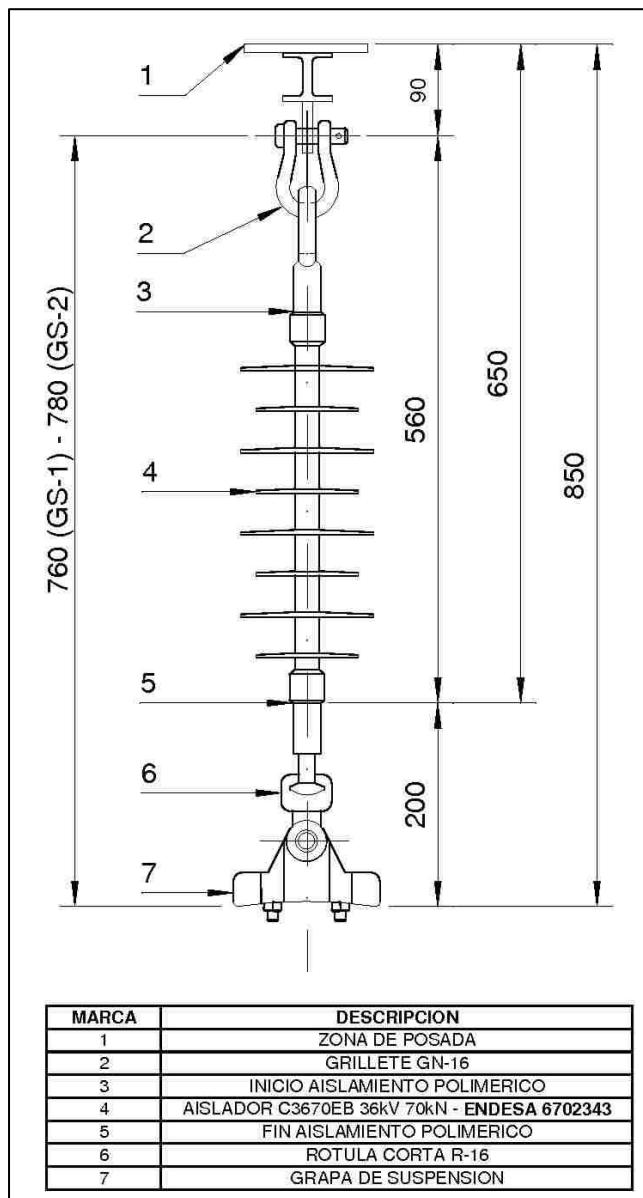

Complete Chain
Ref. CAD36PGS
Alignment

SUSPENSION CHAIN CAD36PGS - WITH INSULATOR Model 36/70EB A - 36 kV 70kN - ENEL STANDARD GSCC010 / Endesa Code 6702343 - TAM 300032

The CAD36PGS chain provides a distance greater than 0.75 m from the conductor to the anchor joint on the crossarm, as required by current regulations for Suspension/Alignment Chains.

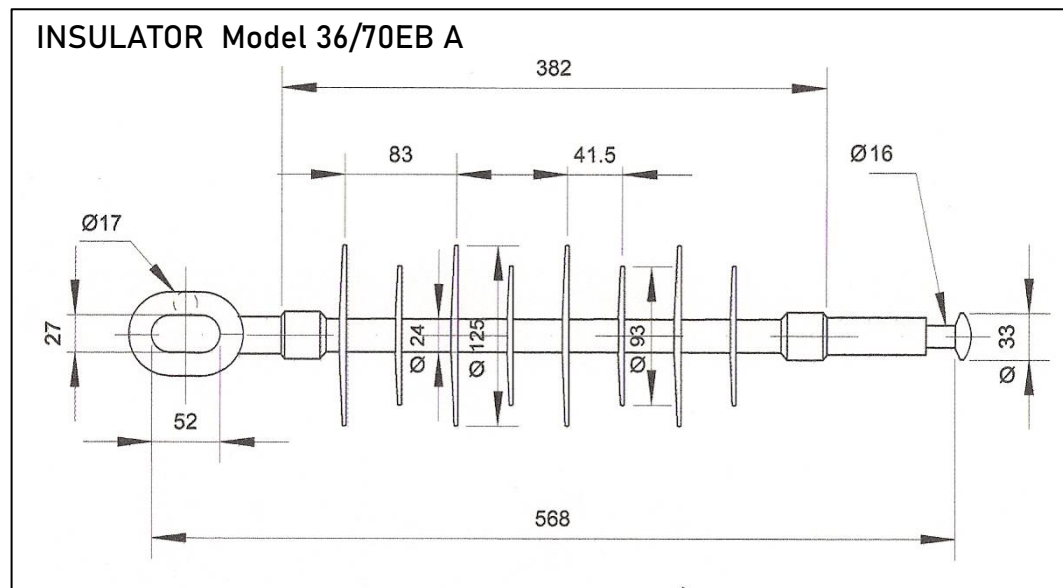

Type Mod.	Service Voltage	Creepage Distance	Dry Arc	CME Mechanic Charge	Test Voltages	
					1,2/50 BIL	50 Hz/ WET
CAON-KORWI C3670EB A	kV	mm	mm	kN	kV	kV
	36	980	415	70	170	70



INSULATOR Model U70YB66P_ALA . INSTALLATION AND MEASUREMENTS ON SUPPORT.

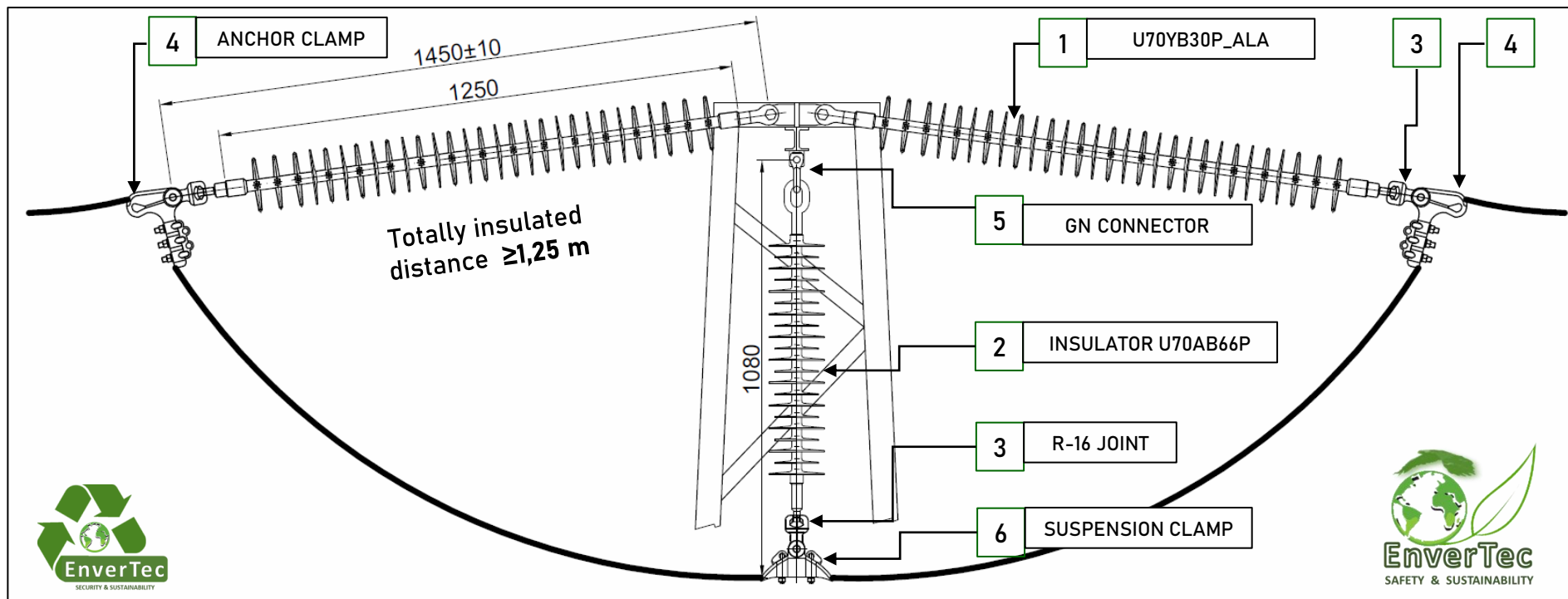

U70YB66P_ALA

- 100% DESIGN BY ENVERTEC S.L. (Granada – Spain).
- Technical specifications and production process monitoring for each batch of insulators.
- Batch Traceability Warranty:
 - Permanent embossed marking with Batch Number and Manufacturing Date.
 - Individual and sample testing according to UNE-EN 61109:2008
 - Quality documentation subject to ISO 17025 standards.





INSULATORS Model U70YB30P_ALA & U70YB66P_ALA . *SPECIAL TESTS.*

OBJECTIVE

To measure and record the leakage current present at various points on the surface of these insulators during the simulation of adverse working conditions.

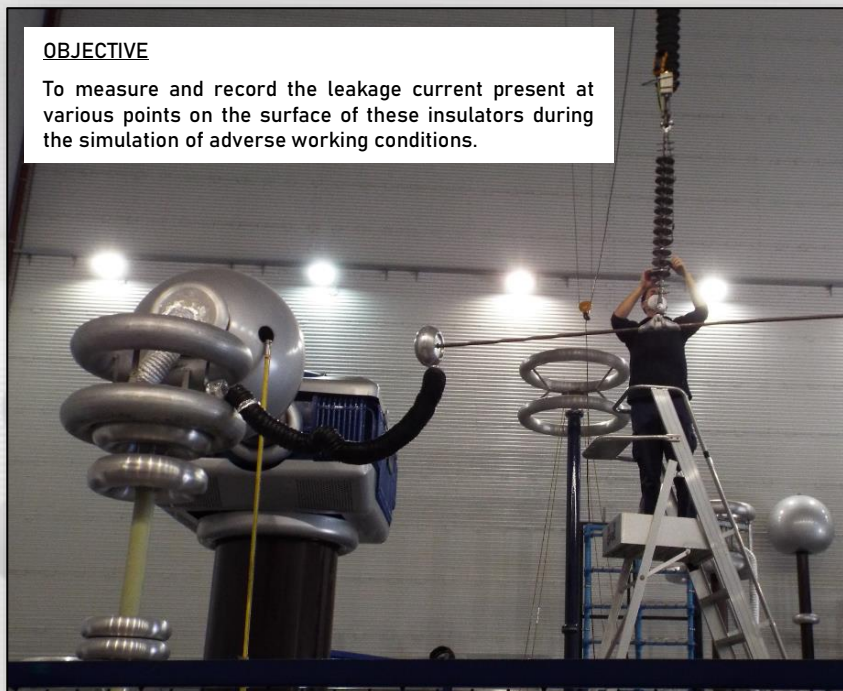

RESULT

The measurements of surface leakage currents taken at various points on these insulators were significantly lower than those obtained from other types of insulator chains. It was also determined that there is a longer completely insulated and safe surface for avifauna in these new models compared to other insulator chains.

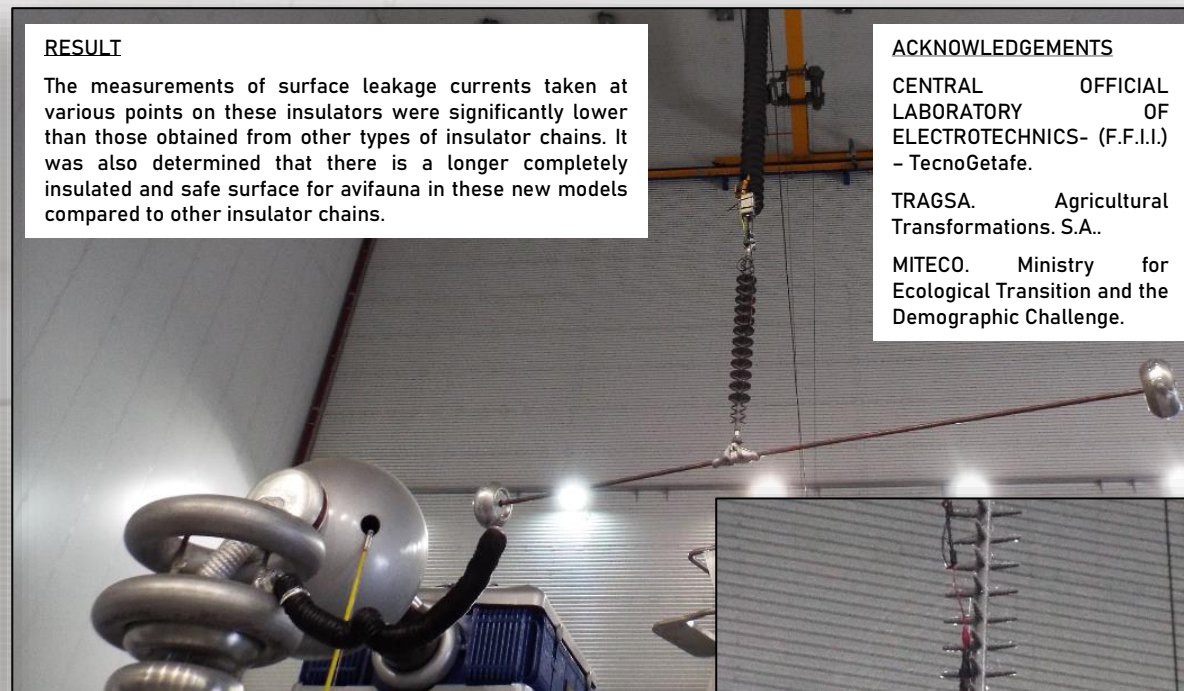

ACKNOWLEDGEMENTS

CENTRAL LABORATORY OF ELECTROTECHNICS- (F.F.I.I.) - TecnoGetafe.

TRAGSA. Agricultural Transformations. S.A..

MITECO. Ministry for Ecological Transition and the Demographic Challenge.

SCOPE

Dielectric Tests at Industrial Frequency Under Rain for assigned voltages of 36 kV and 72 kV.

DATE AND PLACE

Getafe, Madrid, Spain. November 2020.





AVIFAUNA PROTECTION SYSTEMS AND CONTINUITY OF ELECTRIC SERVICE IN MV / HV NETWORKS 15kV – 132kV

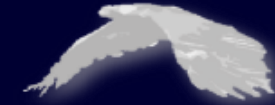

POLYMER PHASE SPACERS CAON-KORWI® _ Models DP – DPS.

INNOVATIVE SOLUTIONS FOR EXISTING LINES _ 15 - 132kV Polymeric Phase Spacers _ *Continuity Systems*.

Lengths $\leq 3,000\text{mm}$ – Conductor Size Range $\varnothing 6 - \varnothing 28\text{mm}$.

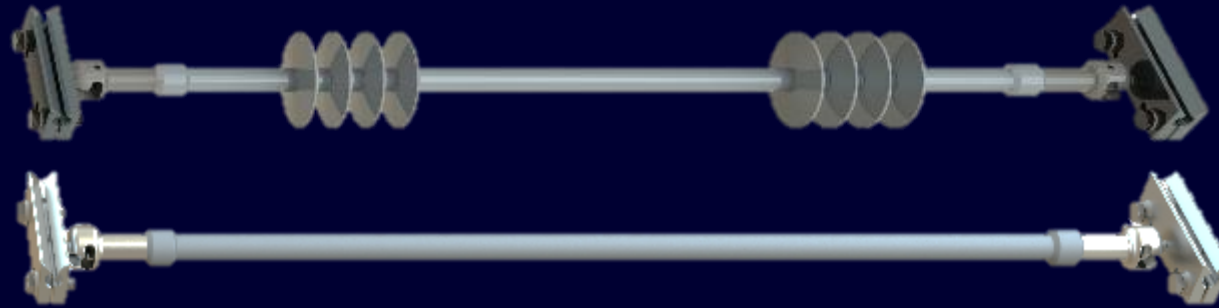

EXCLUSIVE SYSTEM FOR INSTALLATION UNDER LIVE CONDITIONS AND AT A DISTANCE.

Patent Pending

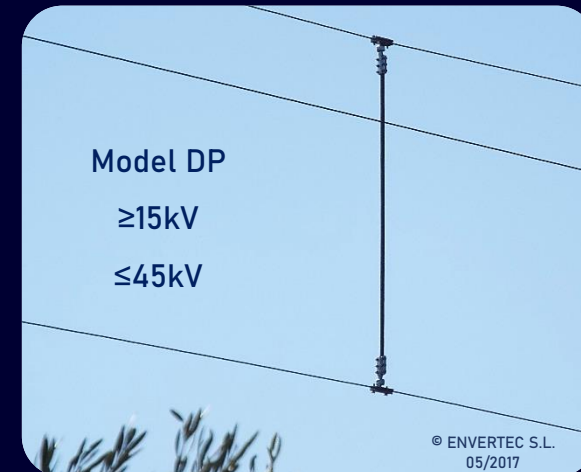
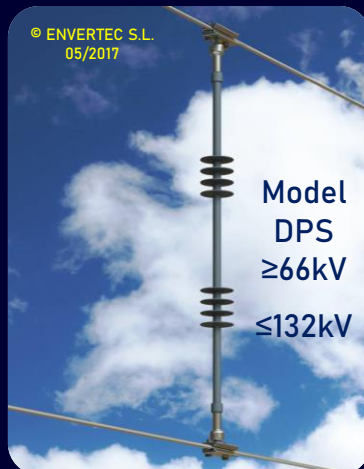

BIRD & INSTALLATION'S PROTECTION INSULATORS. 15 up to 132kV



CHARACTERISTICS AND PERFORMANCE. *SOLUTION TO COLLISIONS BETWEEN CONDUCTORS.*



DPS

DP

OBJECTIVE.

The objective of this development is to present a device that consolidates the results of the design and development work carried out by the Engineering Department of ENVERTEC S.L. regarding Interphase Spacers for Aerial Medium and High Voltage Lines ($\leq 132\text{kV}$).

SCOPE.

The scope of this development is to provide a technical solution to the issues of electrical service interruptions and equipment failures in installations caused by collisions between bare overhead conductors ranging from $\varnothing 6$ to $\varnothing 28$, specifically type LA-31 / LA-455 and ACSR 1/0 - 3/0. These collisions can be triggered by factors such as:

- Loss of tension in the conductors of the line.
- Vibrations of conductors caused by tectonic movements.
- Sudden oscillations of conductors induced by atmospheric phenomena, simultaneous takeoffs of birds, etc.



Source : La Vanguardia 2 019

SCOPE OF APPLICATION.

The scope of application for the CAON®-KORWI® polymeric spacers includes overhead lines equipped with bare conductors with nominal voltages ranging from 15kV to 132kV..

The use of these spacers, positioned in the spans between supports, helps maintain the minimum safety distances between phases for each established voltage level, specifically between 1,000 mm and 3,000 mm, respectively. Our polymeric spacers provide significant cost savings for electric companies by preventing repetitive service interruptions.

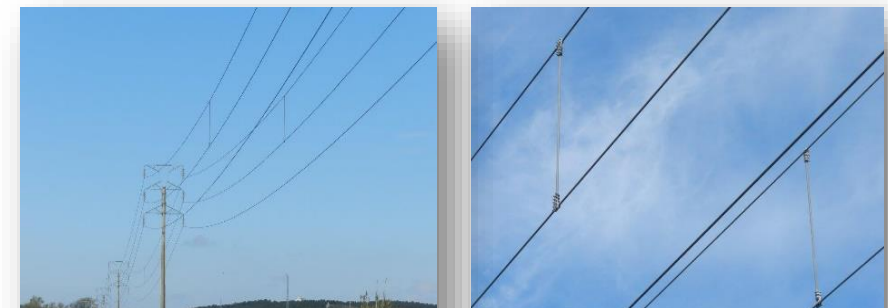

Installations in Northern Spain – July/2016 Network 45/52kV. Total separation distance between phases: 1,400mm



CHARACTERISTICS AND PERFORMANCE. *PREVENTING ELECTRICAL SERVICE INTERRUPTIONS.*



MOST RELEVANT ASPECTS OF THE DESIGN



- INSTALLATION UNDER TENSION AND AT A DISTANCE.
- Our specific clamp, through an EXCLUSIVE system, remains open until it is installed and fixed onto the conductor using poles from a distance. The coupling system of the Anchor Clamp to the fittings of the Spacer is based on the Ball-and-Socket system, in accordance with the IEC60120-11(B) standard. This system allows for easy installation and/or straightforward replacement of the Anchor Clamp on the Spacer..
- The articulation allowed by this coupling system is limited to 5° in all directions, making it suitable for mitigating the effects on the Spacer from sudden movements, whip-like motions, and other oscillations that conductors experience due to various causes:
 - ✓ Atmospheric Phenomena: Wind, storms, etc.
 - ✓ Loss of tension and ground tremors.
 - ✓ Simultaneous take-off of birds.
- The main function of the Spacers is to maintain a minimum safety distance between phases, so the assigned mechanical effort in tension of between 45kN and 70kN is sufficient to effectively fulfill the task at hand and adhere to one of the basic design principles: devices with the least possible weight. This aspect is particularly relevant when the diameter of the cable on which they will be installed is smaller.



Installations in Southern Spain – 2017-2020 Network 15/36kV. Total separation distance between phases: 1.5m – 2.8m.



**POLYMERIC PHASE SPACERS - AVOIDING SERVICE INTERRUPTION.
THE SOLUTION TO THE COLLISION BETWEEN CONDUCTORS.**



MAIN CHARACTERISTICS - DP Series - RECOMMENDED CUT LENGTHS BY VOLTAGE

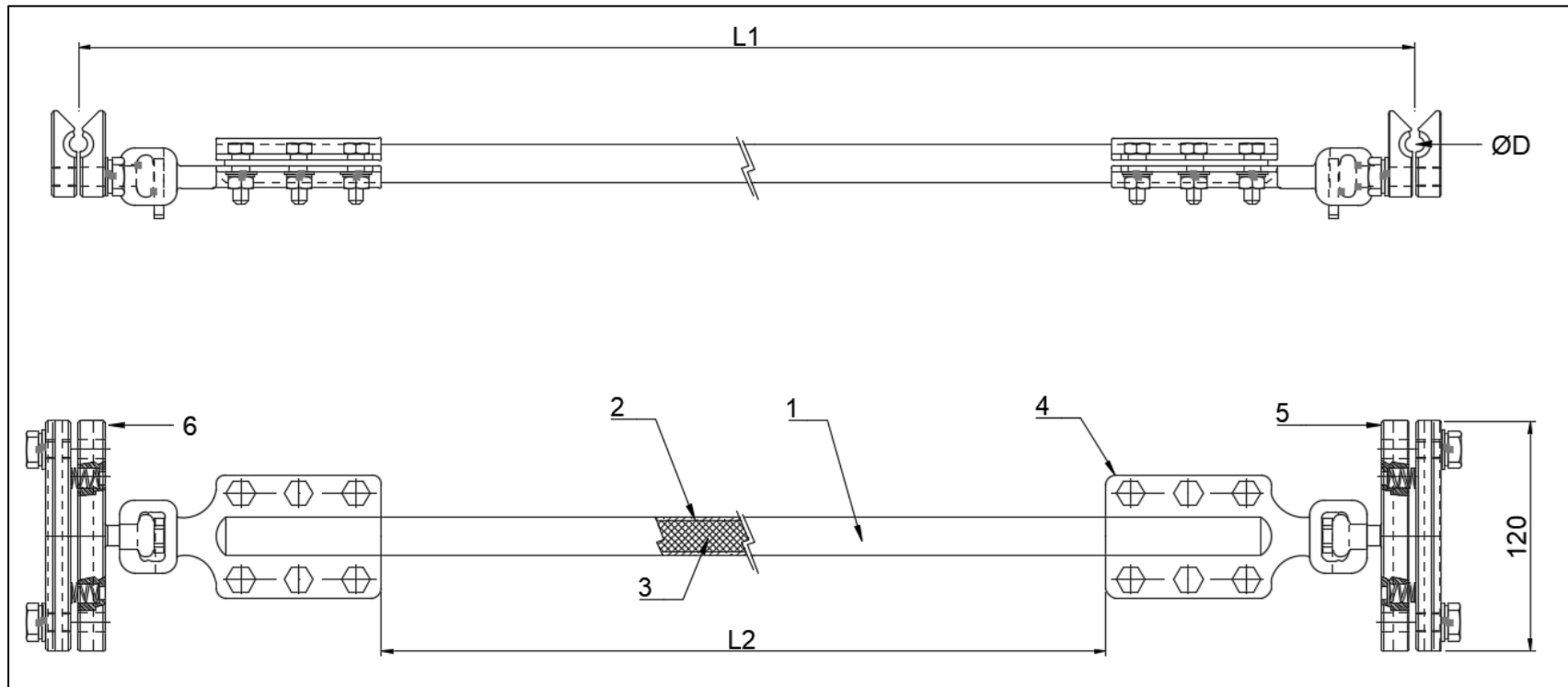

NOMINAL VOLTAGE (kV)	L1 (mm)	L2 (mm)	Test Voltages (kV)	
			1,2/50 BIL	50Hz/WET
≤15	≥655	≥355	140	65
≤20	≥850	≥550	165	70
≤30	≥1280	≥980	215	95
45≤n≤66	≥2550	≥2250	380	165

ITEM	DESCRIPTION	Qty.	MATERIAL / COLOR / RANGE
1	BARRA COMPOSITE 3M20	1	COMPOSITE - GRIS - D20mm - 3m
2	RECUBRIMIENTO DE SILICONA	N/A	HTV - Hc2
3	NÚCLEO RESIST. ÁCIDOS	N/A	RESINA EPOXY REF. CON FIBRA VIDRIO - 45kN
4	ACOPLAMIENTO CPSET-DPF	2	ACERO FORJADO HDG
5	GRAPA ARTICULADA DP-DCLAMP	1	ACERO FORJADO HDG
6	GRAPA ARTICULADA DP-UCLAMP	1	ACERO FORJADO HDG
D	DIÁMETRO DE CONDUCTOR	N/A	Ø7,5 HASTA 16mm



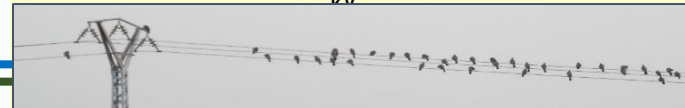

OBJECTIVE OF THE ACTION:

To prevent the electrocution of local avifauna by maintaining the minimum safety distances between phases in overhead medium voltage lines that experience incidents due to the massive presence of birds and simultaneous takeoff, ensuring the continuity of the electric service.

LOCATION :

Mancha Real (Jaén).
La Pagoda - Arroyo Vil
Altitude 770msnm.

INSTALLATION CONDITIONS

WORKING LIVE ON A LIVE LINE

CONDUCTOR: LA-56
(54,6mm²) - Ur. 20kV.

DATE AND TIME:

06/09/2017 _ 10:00 AM / 12:00 PM.

ENVIRONMENTAL CONDITIONS:

DRY _ SUNNY
+20°C.

Acknowledgments:
ENDESA DAOR JAEN
JUAN GALINDO S.L..

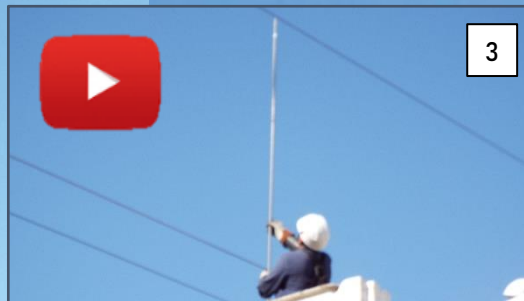

> 3.900PCS IN SERVICE SINCE 2.016

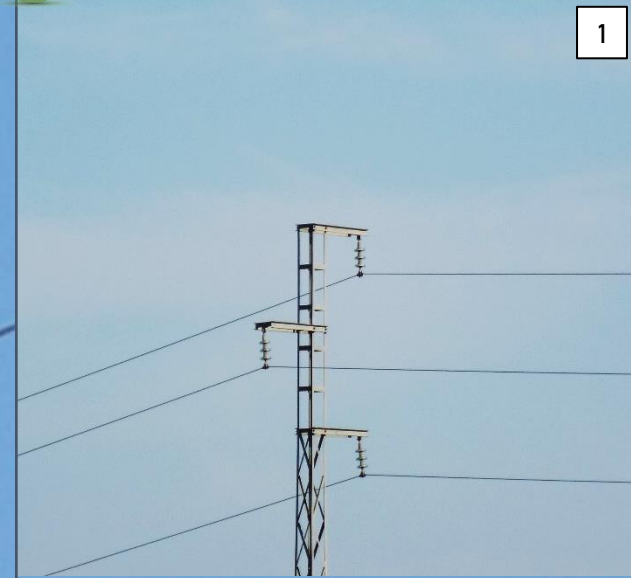

- 1.- Adjustment of the trestle line to 2.40m with tension loss.
 - 2.- Location of the DP Spacer at the span's sag.
 - 3.- Measurement of the distance to be spaced.
 - 4.- Cutting the spacer to the required length.
 - 5.- Fixing the DP Spacer with specific ties.
- EFFECTIVE INSTALLATION TIME: 9 minutes.

INSA_012025

www.birdprotectionsystems.com

+ info : comercial@envertec.eu





INSULATION SYSTEMS IN NETWORKS MV / HV 15kV – 400kV



BRIEF SALES REFERENCES.

➤ 1.000.000pcs Delivered 2014 - 2024

CAON®-KORWI®



International Sale



> 1 000 000pcs delivered 2014 - 2024
 > 1.000.000 Aisladores suministrados.

e-distribución
 Supplier N° 5000001037

i-DE
 Grupo IBERDROLA
 Supplier N° 116.563

Nicaragua
 DISNORTE
 DISSUR



Supplies R.D. Congo



Supplies E-Distribucion/ Enel Spain



Supplies I-DE Spain



Supplies Costa Rica - Mexico - Peru - Nicaragua

- >582.300 units of composite insulators, chain and support, brand CAON®-KORWI® MT/AT supplied only in Spain since 2008, with zero (0) recorded incidents.
 - >240.000 units of MT insulators, chain and support, supplied to ENDESA DISTRIBUCIÓN ELÉCTRICA SLU from 2011 to 2020, with zero (0) recorded incidents, of which >54,700 units were supplied by ENVERTEC S.L. from 2015 to 2020.
 - >225.000 units of MT chain insulators supplied to I-DE REDES ELÉCTRICAS INTELIGENTES S.A.U. in 12/2017-12/2024, with zero (0) recorded incidents.
- > 418.600 units of CAON®-KORWI® composite insulators supplied worldwide (NICARAGUA - PERU - ANGOLA - CONGO), all with zero (0) recorded incidents.



EnverTec





INSULATION SYSTEMS IN NETWORKS MV / HV 15kV – 400kV



THANK YOU VERY MUCH.

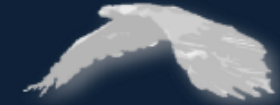

e-distribución
Supplier N° 5000001037

i-DE
Grupo IBERDROLA
Supplier N° 116.563

DISNORTE
DISSUR
Insulation and Equipment

ENVERTEC - CAON PRODUCTION CENTER



ENVERTEC S.L.

Pol. Ind. LA FUENTE
C/ Huelva, parcela nº 10
18340 – Fuente Vaqueros
Granada (Spain)

www.birdprotectionsystems.com



+34 958 511 669

